

Eaton Synflex DIN/ISO Air Brake and Fuel tubing

Advanced technology. Global availability.

Performance proven by DIN/ISO qualification.



EATON

Powering Business Worldwide

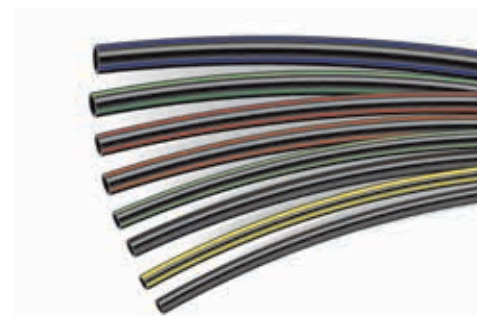

The standard for air brake and fuel tubing products has just been raised.

OEMs and vehicle manufacturers need components they can trust. Over the years, Eaton has set the standard for air brake and fuel tubing innovation.

Our new Synflex DIN/ISO air brake and fuel tubing products are the next step in performance, price competitiveness and availability.

Top performance and ready availability.

Eaton's engineering and materials experts have chosen a thermoplastic material ideally for elevated pressure, high flexibility and wider temperature for truck, bus and trailer air brake and fuel applications. The material, along with Eaton's global manufacturing capability, assures uninterrupted supply and global availability, as well as price stability.

Here's how advanced air brake and fuel tubing is made.

Synflex airbrake and fuel tubing products are made from 100% virgin polyamide PHLY thermoplastic material. The tubing exceeds DIN and ISO performance requirements, including DIN 73378, DIN 74324-1 and ISO 7628. It also meets more stringent OEM customer requirements.

The single wall extrusion of the polyamide thermoplastic material results in a smooth and seamless monowall tubing with a core free from obstruction or foreign materials. It is UV stabilized and also thermoformable for easy assembly.

The tubes are manufactured with many different colored stripes with optimum UV performance, to allow color-coding of an air or fuel system on a vehicle (an aid in assembly and trouble shooting). Standard colors include: Black, Red, Yellow, Green, Blue. Custom colors are available on request.

In addition:

- The Synflex product is designed to operate in a temperature range of -40°C to 100°C (-40°F to 212°F).
- It is designed to operate at a maximum working pressure of 12.5 bar (181 psi).
- The product is resistant to attack by gasoline, diesel fuel, methyl alcohol and zinc chloride (compounds usually present in the operating environment of a vehicle).

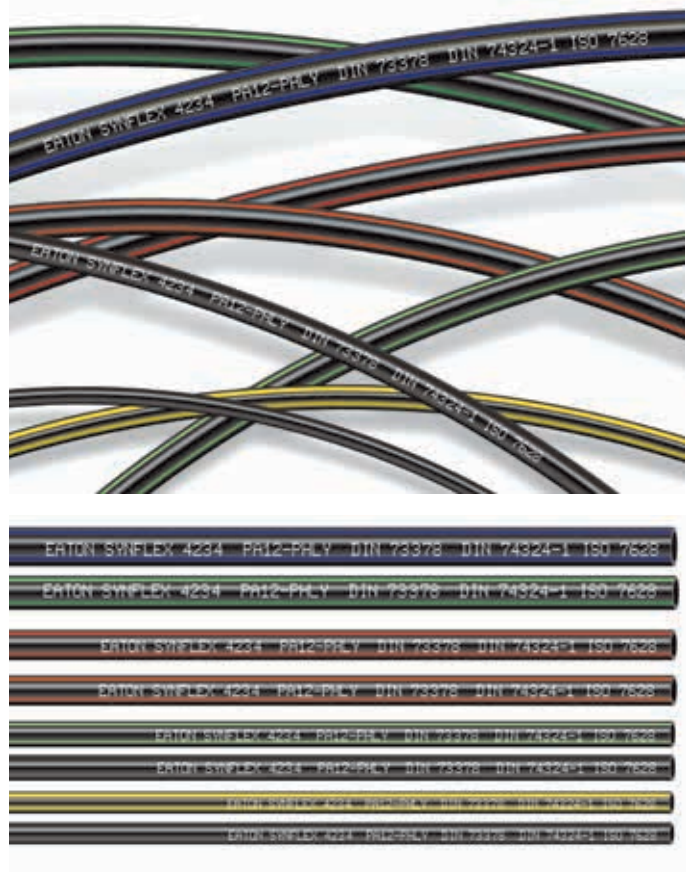

A wide range of applications beyond air brakes and fuel.

In addition to air brake and fuel applications, Synflex tubing can be used for:

- Air conditioning
- CO2 and Air tubing
- Chemical transfer
- Hydraulic lines
- Coolant lines
- Refrigeration
- Compressed Air
- Pneumatic controls
- Lubrication and Oils
- Instrumentation systems

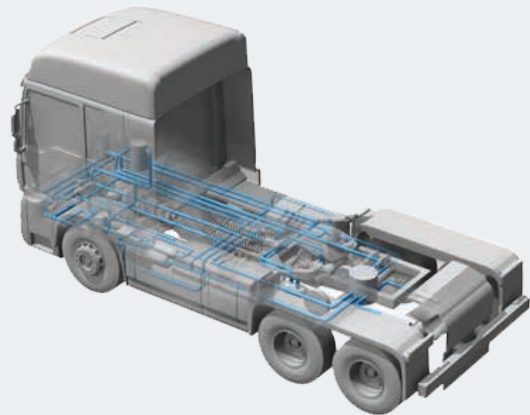

Backed by Eaton expertise that OEMs can trust.

Eaton's technical team has worked closely for years with major OEMs on different vehicle tube applications. Our proven track record with major North American and International customers has led to our manufacturing over 50 million meters of air

brake tubing per year. Our redundant worldwide manufacturing capabilities from Turkey to Brazil assure an uninterrupted supply that users can count on.

Synflex specifications, technical and compliance information.

Standard compliance:

- DIN 73378 Polyamide Tubing for Use in Motor Vehicles
- DIN 74324-1 Polyamide Tubing for Air Braking Systems
- ISO 7628 Road Vehicles – Thermoplastics Tubing for Air Braking Systems

Part Number Set up:

- 4234 = Base part number family (4234=mono-wall, PA12 PHLI tubing)
- 4234-043 = Tubing Outside Diameter x Wall thickness (see technical table below)

- 4234-0430 = Color Identifier (0=Black, 2=Red, 4=Yellow, 5=Green, 6=Blue, etc.)
- 4234-0430B = Package Variable (B=Bulk Lengths, K=Bunch Coils, R=Reels, one per box, etc.)
- 4234-0430B-S = Color Form (S=Black tube wall with longitudinal colored stripes, C=Consistent solid color throughout entire tube wall)
- 4234-0430B-S0100 = Length Variable (0050 = 50m, 0100=100m, 1000 = 1000m, etc.)

Technical table:

# Part number	Nominal I.D.		Nominal O.D.		Operating pressure		Min. burst pressure		Min. bend radius		Weight	
	mm	in	mm	in	bar	psi	bar	psi	mm	in	Kg/m	lbs/100ft
4234-043	2	0.8	4	0.16	12.5	180	180	2611	20	0.79	0.009	0.006
4234-063	4	0.16	6	0.24	12.5	180	108	1566	30	1.18	0.011	0.007
4234-083	6	0.24	8	0.31	12.5	180	77	1119	40	1.57	0.023	0.015
4234-103	8	0.31	10	0.39	12.5	180	60	870	60	2.36	0.029	0.019
4234-104	7.5	0.30	10	0.39	12.5	180	77	1119	60	2.36	0.035	0.024
4234-125	9	0.35	12	0.47	12.5	180	77	1119	60	2.36	0.051	0.034
4234-146	10	0.39	14	0.55	12.5	180	90	1305	75	2.95	0.077	0.052
4234-155	12	0.47	15	0.59	12.5	180	60	870	90	3.54	0.065	0.044
4234-166	12	0.47	16	0.63	12.5	180	77	1119	95	3.74	0.090	0.060
4234-186	14	0.55	18	0.71	12.5	180	68	980	100	3.94	0.103	0.069

Multilayer technology with new developed proprietary thermoplastic material.

In addition to the single-wall tubing featured in this brochure, we offer innovative multilayer Eaton Polyamide Tubes using our own developed proprietary thermoplastic material for air brake and fuel applications.

With our wide experience of multilayer design in accordance with SAE and DOT standards, Eaton developed two different multilayer designs to DIN and ISO standards: a 3-layer design which demonstrates outstanding performance in media and temperature resistance; and a 2-layer design which ideally suits air brake applications.

Thermoplastic material development. Innovation through compounding

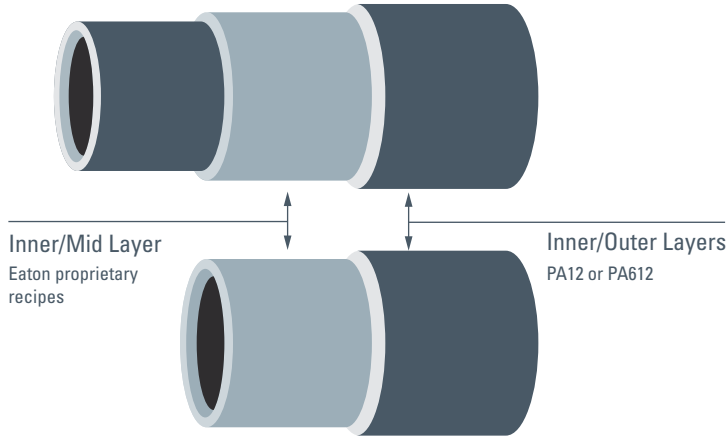

Ask your sales representative for further information on these products.

Eaton
Hydraulics Business USA
14615 Lone Oak Road
Eden Prairie, MN 55344
USA
Tel: 952-937-9800
Fax: 952-294-7722
www.eaton.com/hydraulics

Eaton
Hydraulics Business Europe
Route de la Longeraie 7
1110 Morges
Switzerland
Tel: +41 (0) 21 811 4600
Fax: +41 (0) 21 811 4601

Eaton
Hydraulics Group Asia Pacific
Eaton Building
No.7 Lane 280 Linhong Road
Changning District,
Shanghai 200335
China
Tel: (+86 21) 5200 0099
Fax: (+86 21) 2230 7240