



DIE NEUE DIMENSION DER BEFESTIGUNGSTECHNIK

// ROHRSCHELLEN

BEFESTIGUNGSSYSTEME

// TUBE CLAMPS

FASTENING SYSTEMS

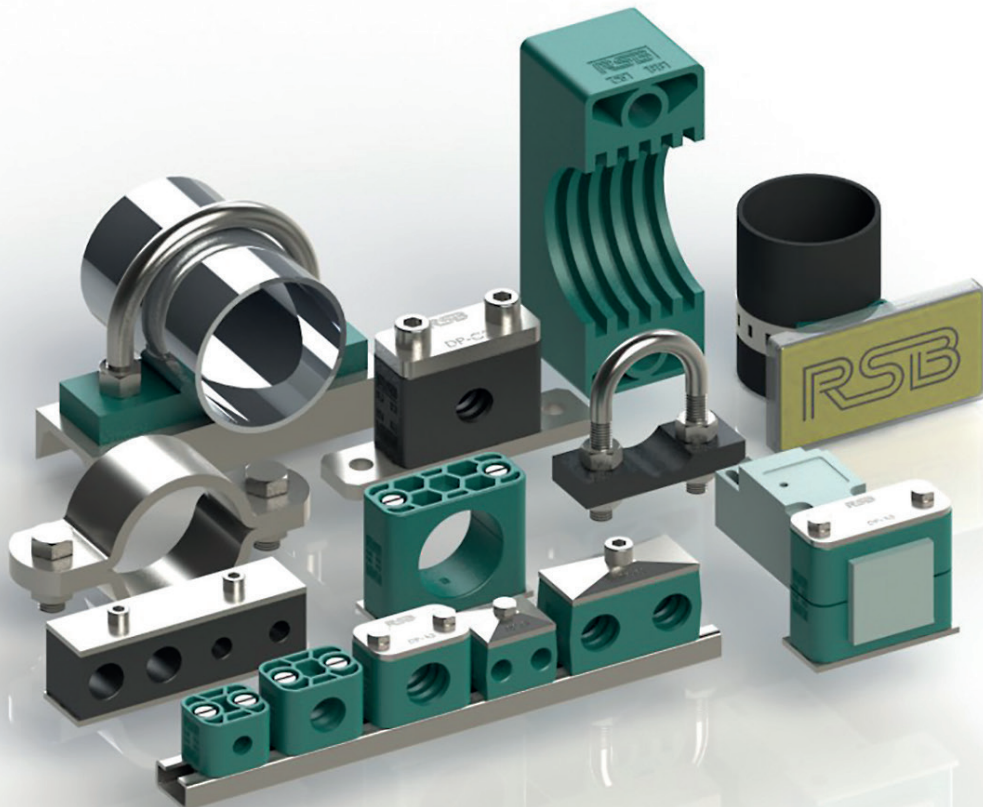

// 01

- 01 – 02 Rohrschellen nach DIN 3015
Tube clamps acc. to DIN 3015
- 03 Werkstoffeigenschaften
Material properties
- 04 – 05 Sonderwerkstoffe für Rohr- und Schlauchschellen
Special-materials for tube- and hose clamps
- 08 Montagehinweise
Assembly instructions
- 09 – 10 Technische Daten
Technical data

// 03

- 29 – 35 Rohrschellen Serie B
Tube clamps Series B



// 05

- 60 – 65 Rohrschellen mit Schalldämmeinlage
Tube clamps with noise protection insert



// 07

- 79 – 82 Hydraulik-Stahlschelle
Hydraulic steel clamp
- 83 – 86 Visitec Schlauchführung
Visitec hose guide
- 87 – 88 Stahl-Konstruktionsschelle mit Rohrunterlagen
Steel-construction clamp with tube saddles
- 89 – 90 Flachstahlbügel
Flat steel U-bolts
- 91 – 95 Rundstahlbügel und Rohrunterlagen
U-bolts and tube saddles
- 96 Flachstahl-Rohrschellen
Flat steel tube clamps

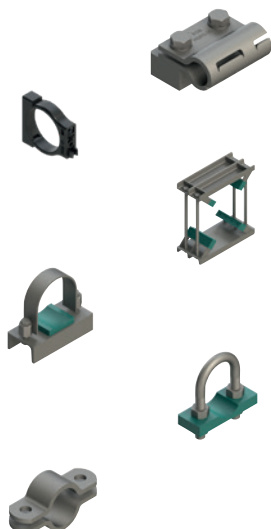

// 02

- 11 – 25 Rohrschellen Serie A
Tube clamps Series A
- 12 – 13 Der Korrosionshemmer – Rohrschellen aus PP-CR
The corrosion inhibitor – clamps made of PP-CR
- 20 Sensorschellen Serie A
Sensor clamps Series A
- 26 – 27 2+5 ... das System
2+5 ... the system
- 67 – 71 Multischellen
Multiclamps



// 04

- 37 – 48 Rohrschellen Serie C
Tube clamps Series C
- 49 – 52 Doppelschelle schwere Baureihe
Twin clamp heavy series
- 53 – 56 Befestigungsadapter
Fixed adaptor
- 57 – 58 Eine Schiene für alle
One rail for all



// 06

- 72 – 74 Rohrschellen Serie O
Tube clamps Series O
- 75 – 78 Rohrbefestigung auf einem Zylinder
Tube fastening on a cylinder

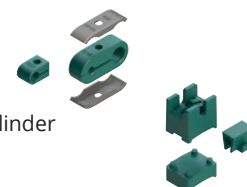

// 08

- 97 – 98 Bezeichnungssystem
Labeling system



// AUSFÜHRUNGEN

// TYPES

Ausführung der Schellenkörper

Als Werkstoff für Schellenkörper sind ab Lager lieferbar:

- Polypropylen (Farbe dunkelgrün)
- Polyamid 6 (Farbe schwarz)
- TPE (Farbe schwarz)
- Aluminium

Die oberen und unteren Schellenhälften sind identisch. Die Innenseite der Schellen ist mit Rippen oder in glatter Ausführung lieferbar.

Rippen in der Innenfläche der Schellen wirken schlag- und vibrationsdämmend und nehmen Kräfte in Rohrachrichtung auf. Ein Spalt zwischen den Hälften bewirkt die Vorspannung des Rohres.

Für die Halterung von Schläuchen und Kabeln wird die Verwendung von Schellen mit glatter Innenfläche ohne Vorspannung empfohlen. Das Spaltmaß s_1 entfällt. Dadurch reduziert sich die Blockhöhe h_1 .

Types of clamp bodies

The clamp bodies are available in these materials ex store:

- Polypropylene (dark green colour)
- Polyamide 6 (black colour)
- TPE (black colour)
- Aluminium

Upper and lower clamp halves are identical.

The inside of the clamp is available with or without grooves.

Grooves on the inside of the clamps have a vibration and impact reducing effect and absorb force towards the direction of the tube axis.

A spacing between both halves produces the prestress of the tube.

For the support of hoses and cables, we recommend to use clamps with an even inside without prestress. The spacing measure s_1 is not required. Thus, the block height h_1 is reduced.



Ausführung der Metallteile

Bei Serie A und B sind standardmäßig Schrauben, Schienenmutter und Deckplatten Chrom VI-frei verzinkt, Anschweißplatten phosphatiert, Tragschienen blank.

Bei Serie C sind standardmäßig alle Metallteile blank und phosphatiert.

Sämtliche Metallteile der einzelnen Baureihen sind in Edelstahlqualität W5 (AISI 316), ab Lager lieferbar.

Vom Standard abweichende Oberflächenbehandlung liefern wir auf Anfrage.

UNC-Gewinde sind auf Anfrage lieferbar.

Types of metal parts

As a regular feature of series A and B clamps, screws, rail nuts and cover plates are chromium VI free zinc coated, welding plates phosphatized and mounting rails uncoated.

As a regular feature of series C clamps, all metal parts are uncoated and phosphatized.

All metal parts of the different construction series are available ex stock in stainless steel type W5 (AISI 316).

Other surface treatments are available upon request.

UNC-threads are available upon request.

Metrisches Gewinde Metric thread	entsprechendes UNC-Gewinde corresponding UNC-thread
M 6	1/4 - 20 UNC
M 8	5/16 - 18 UNC
M 10	3/8 - 16 UNC
M 12	7/16 - 14 UNC
M 16	5/8 - 11 UNC
M 20	3/4 - 10 UNC
M 24	7/8 - 9 UNC
M 30	1 1/8 - 7 UNC

// FESTIGKEITSKLASSEN

// STRENGTH CLASSES

Schraubenart Type of screw	Werkstoff Material	Festigkeitsklasse Strength class
Schlitzschraube SL Slotted head screw SL	Stahl / Steel	4.8 (nach DIN EN ISO 898-1)
	A2	A2-70 (nach DIN EN ISO 3506-1)
	A4	A4-70 (nach DIN EN ISO 3506-1)
Sechskantschraube SSL/SS Hexagon head screw SSL/SS	Stahl / Steel	8.8 (nach DIN EN ISO 898-1)
	A2	A2-70 (nach DIN EN ISO 3506-1)
	A4	A4-70 (nach DIN EN ISO 3506-1)
Innensechskantschraube IS Hexagon socket head screw IS	Stahl / Steel	8.8 (nach DIN EN ISO 898-1)
	A2	A2-70 (nach DIN EN ISO 3506-1)
	A4	A4-70 (nach DIN EN ISO 3506-1)

// BESTELLZEICHEN

In die Bestellzeichen für RSB-Schellenhälften sowie für komplette Rohrschellen ist die Serienbezeichnung, die Werkstoffbezeichnung und die Form der Innenfläche eingearbeitet.

Bezeichnungsbeispiel:

Schellenkörper

R A N G M - 3 20 / F

R	A	N	G	M	-	3	20	/	F
									Merkmale F = flammgeschützt CR = korrosionshemmend z.B. Sh64° = 64°Shore
								Durchmesser	Diameter
							Schellengröße	Clamp size	
Variante M = Multi, E = Schalldämmeinlage, S = Viereckig (Sensor), A = Abweichend vom Standard									
Innenfläche R = Rippen, G = Glatt, E = für Einsatz geeignet, A = Abweichend vom Standard									
Werkstoff P = Polypropylen, N = Polyamid, V = TPE, A = Aluminium, X = Edelstahl									
Serie A = Leichtbaureihe, B = Zweirohrschelle, C = Schwere Baureihe, O = Rohrschelle Serie O									
Rohrschelle / Schellenkörper									

// Vollgummi bei Serie A und B, glatte Innenfläche
 // Aluminium bei Serie A Größe 0 bis 6 und Serie C Größe 1 bis 8
 // Glatte Innenfläche bei Serie C bis Größe 8, Schellen aus Aluminium mit Rippen (R), Glatte Innenfläche bei Serie A Größe 1 bis 8

Zubehör / Metallteile

AP K Z1 - A 3 / CRVIF

AP	K	Z1	-	A	3	/	CRVIF
							Merkmale Zn = verzinkt; CRVIF = chrom VI frei; Phos = phosphatiert; /1.4571 = Edelstahl / Schrauben Mat. A4; /1.4301 = Edelstahl / Schrauben Mat. A2; AL = Aluminium; UNC = UNC-Gewinde
						Baugröße oder abweichende Maße (z.B. Schrauben)	Size or different measure (e.g. screws)
Serie A = Leichtbaureihe, B = Zweirohrschelle, C = Schwere Baureihe, O = Rohrschelle Serie O							
Ausführung Z1, Z2, Z3							
Variante D = Doppelt, R = Reihe, W = Winkel, M = Multi, K = Kurz, L = Lang/Verlängert							
Bezeichnung AP = Anschweißplatte, DP = Deckplatte, TS = Tragschiene, SB = Sicherungsblech, TM = Tragschienenmutter, TM-A/B = Visitec Tragschienenmutter, US = Sicherungsscheibe, SP = Sicherungsplatte, SL = Schlitzschraube, SSL/SS = Sechskantschraube, IS = Innensechskantschraube, AS = Aufbauschraube, SBR = Sicherungsblech							

Zulassungen

DNV-GL, Lloyd's Register of Shipping, Bureau Veritas, ABS (American Bureau of shipping)

// ORDER CODES

The order codes for RSB clamp-halves as well as for complete tube clamps incorporate the serial indication, material description and interior surface.

Example of description:

Clamp bodies

R A N G M - 3 20 / F

R	A	N	G	M	-	3	20	/	F
									Features F = Flame-protected CR = corrosion retardant e.g. Sh64° = 64°Shore
								Diameter	Diameter
							Clamp size	Clamp size	
Version M = Multi, E = Noise protection insert, S = Square (Sensor), A = Different from the standard									
Interior surface R = Grooved, G = Smooth, E = Suitable for insert, A = Different from the standard									
Material P = Polypropylene, N = Polyamide, V = TPE, A = Aluminium, X = Stainless steel									
Series A = Light construction series, B = Twin-tube series, C = Heavy duty series, O = Tube clamps series O									
Tube clamp									

// Rubber for series A and B, inside smooth
 // Aluminium for series A size 0 to 6 and series C size 1 to 8
 // Smooth interior surface in series C to size 8, Aluminium clamps in a grooved design (R), Inside smooth series A size 1 to 8

Accessories / metal parts

AP K Z1 - A 3 / CRVIF

AP	K	Z1	-	A	3	/	CRVIF
							Features Zn = zinc plated; CRVIF = chromium VI free; Phos = phosphated; /1.4571 = stainless steel / screws Mat. A4; /1.4301 = stainless steel / screws Mat. A2; AL = Aluminium; UNC = UNC thread
						Size or different measure (e.g. screws)	Size or different measure (e.g. screws)
Serie A = Light construction series, B = Twin-tube series, C = Heavy duty series, O = Tube clamps series O							
Version Z1, Z2, Z3							
Types D = double, R = multiple, W = angle, M = multi, K = short, L = long/elongated							
Name AP = Weld plate, DP = Cover plate, TS = Mounting rail, SB = Locking plate, TM = Rail nut, TM-A/B = Visitec rail nut, US = Locking washer, SP = Locking plate, SL = Slotted head screw, SSL/SS = Hexagon head screw, IS = Hexagon socket head screw, AS = Stacking bolt, SBR = Locking plate							

Registration

DNV-GL, Lloyd's Register of Shipping, Bureau Veritas, ABS (American Bureau of shipping)

// WERKSTOFFEIGENSCHAFTEN

// MATERIAL PROPERTIES

MECHANISCHE EIGENSCHAFTEN MECHANICAL PROPERTIES	<i>Polypropylen</i> <i>Polypropylene (PP)</i>	<i>Polyamid</i> <i>Polyamide (PA 6)</i>	<i>Aluminium</i> <i>Aluminium (Al)</i>	<i>Thermoplastisches Elastomer</i> <i>Thermoplastic elastomer</i>
Dichte / Density	0,90 g/cm ³	1,10 g/cm ³	2,65 g/cm ³	0,97 g/cm ³
Kerbschlagzähigkeit nach Charpy bei 23 °C Impact value at 23 °C	7 kJ/m ² (ISO 179/1eA)	8 kJ/mm ² (ISO 179/1eA)		
Kerbschlagzähigkeit nach Charpy bei -20 °C Impact value at -20 °C	3 kJ/m ² (ISO 179/1eA)			
E-Modul (Zug) Modulus of elasticity	1.400 N/mm ² (ISO 527)	2.000 N/mm ² (ISO 527)	72.000 N/mm ²	
Streckspannung bzw. Zugfestigkeit (Rm) Yield stress resp. tensile strength (Rm)	28 N/mm ² (ISO 527)	50 N/mm ² (ISO 527)	>240 N/mm ²	5,2 ... 8,8 N/mm ² (ASTM D412)

THERMISCHE EIGENSCHAFTEN THERMAL PROPERTIES	<i>Polypropylen</i> <i>Polypropylene (PP)</i>	<i>Polyamid</i> <i>Polyamide (PA 6)</i>	<i>Aluminium</i> <i>Aluminium (Al)</i>	<i>Thermoplastisches Elastomer</i> <i>Thermoplastic elastomer</i>
Temperaturbeständigkeit / Temperature resistance	-30 ... +90°C	-40 ... +120°C	-40 ... +300°C	-50 ... +120°C

CHEMISCHE EIGENSCHAFTEN CHEMICAL PROPERTIES	<i>Polypropylen</i> <i>Polypropylene (PP)</i>	<i>Polyamid</i> <i>Polyamide (PA 6)</i>	<i>Aluminium</i> <i>Aluminium (Al)</i>	<i>Thermoplastisches Elastomer</i> <i>Thermoplastic elastomer</i>
Säuren / Weak acids	bedingt beständig limited resistant	bedingt beständig limited resistant	bedingt beständig limited resistant	beständig resistant
Laugen / Weak alkalis	bedingt beständig limited resistant	bedingt beständig limited resistant	bedingt beständig limited resistant	beständig resistant
Alkohole / Alcohol	beständig resistant	beständig resistant	beständig resistant	beständig resistant
Benzin / Petrol	bedingt beständig limited resistant	beständig resistant	beständig resistant	bedingt beständig limited resistant
Mineral-Öl / Mineral oils	bedingt beständig limited resistant	beständig resistant	beständig resistant	beständig resistant
Sonstiges Öl / Other oils	beständig resistant	beständig resistant	beständig resistant	beständig resistant

Die genannten Daten sind Durchschnittswerte und gelten nur als unverbindliche Hinweise, auch in Bezug auf etwaige Schutzrechte Dritter, und befreien Sie nicht von der eigenen Prüfung der von uns gelieferten Produkte auf ihre Eignung.

Diese Werte können nur bedingt zu Konstruktionszwecken verwendet werden.

Die Anwendung der Produkte erfolgt außerhalb unserer Kontrollmöglichkeiten und liegt daher ausschließlich in Ihrem Verantwortungsbereich. Sollte dennoch eine Haftung in Frage kommen, so ist dies für alle Schäden auf den Wert der von uns gelieferten und von Ihnen eingesetzten Ware begrenzt.

Selbstverständlich gewährleisten wir die einwandfreie Qualität unserer Produkte nach Maßgabe unserer Allgemeinen Verkaufs- und Lieferbedingungen.

The outlined particulars are approximate values and are only valid as references, which are not binding, also with regard to possible protection of third parties, and they do not exempt you from your own examination of suitability of the products delivered by us.

Therefore, these values can only be used in a limited sense for construction purposes.

The application of the products is carried out outside our control, and therefore, is exclusively subject to your own area of responsibility. If, however, liability should be possible, it would be limited for all damages to the value of the goods supplied by us and in use by you.

It goes without saying, that we guarantee the perfect quality of our products according to our general sales and delivery conditions.

// VORBEUGENDER BRANDSCHUTZ

// PREVENTIVE FIRE PROTECTION

<i>Material:</i> <i>Material:</i>		PA66-F
EN 45545-2		
T01 EN ISO 4589-2:	Sauerstoffgehalt Oxygen Index	OI = 35,5%
T10.03 EN ISO 5659-2:	25 kW/m ²	D ₅ max. = 124
T12 NF X 70 100-1 & -2:	600 °C	CIT _{NLP} = 0,51
Erfüllung des Anforderungssatzes R22 für die Gefährdungsstufe: Compliance of the requirement set R22 for the hazard level:		HL1 – HL2 – HL3
Erfüllung des Anforderungssatzes R23 für die Gefährdungsstufe: Compliance of the requirement set R23 for the hazard level:		HL1 – HL2 – HL3
Erfüllung des Anforderungssatzes R24 für die Gefährdungsstufe: Compliance of the requirement set R24 for the hazard level:		HL1 – HL2 – HL3
Erfüllung des Anforderungssatzes R26 für die Gefährdungsstufe: Compliance of the requirement set R26 for the hazard level:		HL1 – HL2 – HL3

<i>Material:</i> <i>Material:</i>		PP-F
EN 45545-2		
T01 EN ISO 4589-2:	Sauerstoffgehalt Oxygen Index	OI = 38,7%
T10.03 EN ISO 5659-2:	25 kW/m ²	D ₅ max. = 48
T12.NF X 70 100-1 & -2:	600 °C	CIT _{NLP} = 0,15
Erfüllung des Anforderungssatzes R22 für die Gefährdungsstufe: Compliance of the requirement set R22 for the hazard level:		HL1 – HL2 – HL3
Erfüllung des Anforderungssatzes R23 für die Gefährdungsstufe: Compliance of the requirement set R23 for the hazard level:		HL1 – HL2 – HL3
Erfüllung des Anforderungssatzes R24 für die Gefährdungsstufe: Compliance of the requirement set R24 for the hazard level:		HL1 – HL2 – HL3
Erfüllung des Anforderungssatzes R26 für die Gefährdungsstufe: Compliance of the requirement set R26 for the hazard level:		HL1 – HL2 – HL3

Weitere Brandschutzprüfungen auf Anfrage.
 Further fire safety tests on request.

<i>Material:</i> <i>Material:</i>		TPE-F
EN 45545-2		
T01 EN ISO 4589-2	Sauerstoffgehalt Oxygen Index	OI = 33,4%
T10.03 EN ISO 5659-2:	25 kW/m ²	D _s max. = 79
T12 NF X 70 100-1 & -2:	600 °C	CIT _{NLP} = 0,15
Erfüllung des Anforderungssatzes R22 für die Gefährdungsstufe: Compliance of the requirement set R22 for the hazard level:		HL1 - HL2 - HL3
Erfüllung des Anforderungssatzes R23 für die Gefährdungsstufe: Compliance of the requirement set R23 for the hazard level:		HL1 - HL2 - HL3
Erfüllung des Anforderungssatzes R24 für die Gefährdungsstufe: Compliance of the requirement set R24 for the hazard level:		HL1 - HL2 - HL3
Erfüllung des Anforderungssatzes R26 für die Gefährdungsstufe: Compliance of the requirement set R26 for the hazard level:		HL1 - HL2 - HL3

SCHIFFSBAU UND OFFSHORE LÖSUNGEN

KORROSIONSHEMMEND UND SCHALLDÄMMEND | NACH DIN 3015

SHIPBUILDING AND OFFSHORE SOLUTIONS

CORROSION-INHIBITING AND SOUND-ABSORBING | IN ACCORDANCE WITH DIN 3015

DIE LÖSUNG FÜR SCHIFFSBAU UND OFFSHORE

- Vibrationsdämmung und Körperschall-entkopplung im System
- Korrosionsschutz getestet gemäß DIN EN ISO 9227
- Längere Standzeiten
- Höhere Wartungsintervalle
- Längere Lebensdauer der Rohre und Hydraulikleitungen

THE SHIPBUILDING AND OFFSHORE SOLUTION

- Systematic vibration insulation and structure-borne sound insulation
- Certified corrosion inhibitor in line with DIN EN ISO 9227
- Longer service life
- Increased maintenance intervals
- Greater durability of tubes and hydraulic lines

IN DER NORM KONFORM ZULASSUNGEN

- DNV-GL
- ABS (American Bureau of shipping)
- Bureau Veritas
- Lloyd's Register of Shipping

STANDARDS COMPLIANCE APPROVALS

- DNV-GL
- ABS (American Bureau of shipping)
- Bureau Veritas
- Lloyd's Register of Shipping

PRODUKTE PRODUCTS

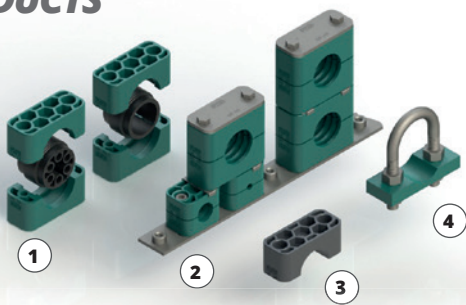

- | | |
|---------------------------------------|---|
| 1. Rohrschellen mit Schalldämmeinlage | 1. Tube clamps with noise protection insert |
| 2. Rohrschellen Serie 2+5 | 2. Tube clamps series 2+5 |
| 3. PP-CR®-Schelle | 3. PP-CR® tube clamp |
| 4. Rundstahlbügel | 4. U-bolt |

DER KORROSIONSHEMMER ROHRSCHELLEN AUS PP-CR®

EDELSTAHLROHR (1.4571) NACH 4500 STD. SALZSPRÜHNEBELTEST

THE CORROSION INHIBITOR TUBE CLAMPS MADE FROM PP-CR®

STAINLESS STEEL TUBE (1.4571) AFTER 4,500 HOURS SALT SPRAY TEST

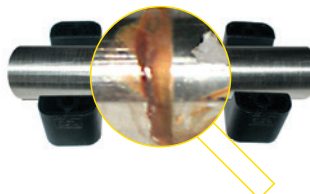

Resultat mit
Standard-Polypropylen
Result with
standard polypropylene

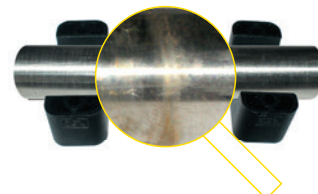

Resultat mit PP-CR®
Result with PP -CR®

SICHERHEIT MIT SYSTEM!

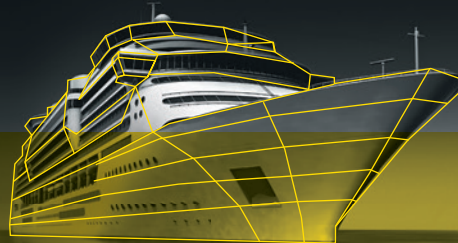

FLAMMGESCHÜTZTE ROHRSCHELLEN

FÜR ERHÖHTE SICHERHEIT VON SCHIENEN-
FAHRZEUGEN | NACH DIN 3015

FLAME PROTECTED TUBE CLAMPS

FOR IMPROVED RAILWAY VEHICLE SAFETY | IN ACCORDANCE WITH DIN 3015

DIE VORTEILE

- Mehr Sicherheit für Schienenfahrzeuge
- Flammgeschützt nach EN 45545-2, UL 94
- System 2+5. Nur 2 Baugrößen für die Rohrdurchmesser 6 – 42 mm
- Platten und Schienen in Stahl und Edelstahl

IN DER NORM KONFORM

FLAMMGESCHÜTZTE ROHRSCHELLEN
NACH DIN 3015 GEPRÜFT GEMÄSS

- EN 45545-2
- UL 94

MIT SYSTEM FÜR HÖHERE SICHERHEIT!

Das bekannte Rohrschellen-Programm von RSB® ist jetzt durch die flammgeschützte Ausführung die ideale Lösung für den Transport- und Railway-Markt. Das bedeutet mehr Sicherheit und Effizienz für Schienenfahrzeuge.

THE ADVANTAGES

- Improved railway vehicle safety
- Flame protected in accordance with EN 45545-2, UL 94
- 2+5 system. Only 2 sizes for tube diameters 6 – 42 mm
- Plates and rails in steel and stainless steel

STANDARDS COMPLIANCE

FLAME PROTECTED TUBE CLAMPS
DIN 3015 CERTIFICATION IN LINE WITH

- EN 45545-2
- UL 94

SYSTEMATIC FOR IMPROVED SAFETY!

The well-known tube clamp range from RSB® has just got bigger. Now available as a flame protected version, it is the ideal solution for the transport and railway market. This means improved safety and efficiency for rail vehicles.

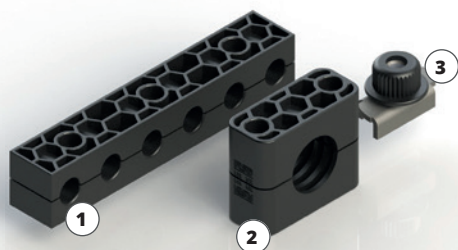

PRODUKTE PRODUCTS

1. Multischelle Serie A
2. Rohrschelle Serie A
3. Visitec

1. Multiclamp series A
2. Tube clamp series A
3. Visitec

SICHERHEIT MIT SYSTEM!



// MONTAGE

// ASSEMBLY INSTRUCTION

Montage auf Anschweißplatten

Anschweißplatten auf einer mit der Belastung abgestimmten Unterlage anschweißen. Hierbei ist auf die Ausrichtung der Schelle zu achten. Untere Schellenhälfte auf Anschweißplatte klemmen, Rohr einlegen, zweite Schellenhälfte aufsetzen und mit den Schrauben festziehen. Auf Vorspannung achten (Schellenhälften dürfen sich nach der Montage nicht berühren)! Nicht mit aufgesetzter Kunststoff-Schelle schweißen! Verlängerte Anschweißplatten können mit der Unterlage verschraubt werden.

Assembly on metal welding plates

Place welding plates on a base appropriate for the load. Make sure that the clamps are properly aligned. Clamp lower clamp half onto welding plate, insert tube, place upper clamp half onto lower half and fasten with the screws. Attention must be paid to the prestress (after completed assembly, clamp halves must not be in contact)! Do not weld with fitted plastic clamp! Extended welding plates may be screwfastened to the base.

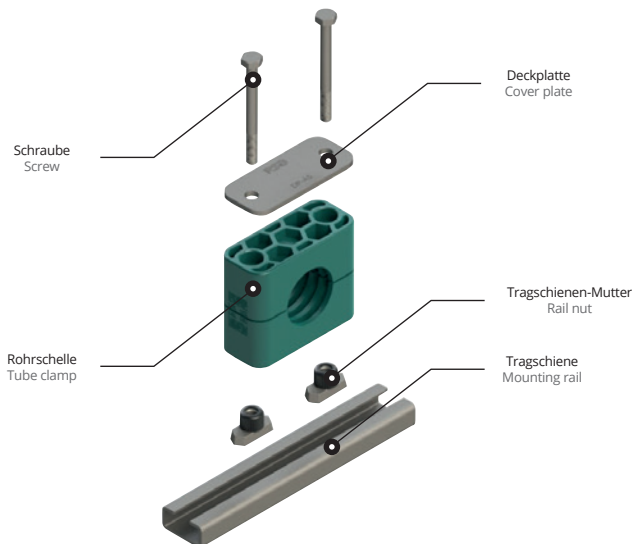
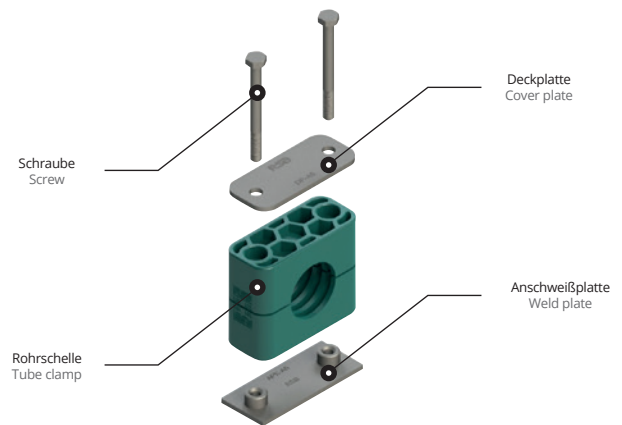

Montage auf Tragschienen

Tragschienen sind in vier unterschiedlichen Höhen verfügbar und werden wahlweise in Stücken zu 1 oder 2 m geliefert. Tragschiene anschweißen oder mit Befestigungswinkel anschrauben. Tragschienenmutter in Schiene einführen und bis zum Anschlag drehen. Bei schwerer Baureihe nur einschieben. Untere Schellenhälfte auf Tragschienenmutter aufkleben, Rohr einlegen, zweite Schellenhälfte aufsetzen und mit den Schrauben festziehen. Vor dem Festziehen der Schrauben ist eine Positionierung der Schelle möglich. Auf Vorspannung achten (Schellenhälften dürfen sich nach Montage nicht berühren)!

Assembly on mounting rails

Mounting rails are available in four different heights and come in pieces of 1m or 2 m length, as required. Weld on mounting rail or screw-fasten with fastening angle bracket. Insert mounting rail nuts in rail and turn until stop. For heavy duty construction series, nuts are simply pushed in. Clamp lower clamp half on mounting rail nuts, insert tube, place upper clamp half onto lower half and fasten with the screws. Before fastening the screws, the clamp may still be positioned. Attention must be paid to the prestress (after completed assembly, the clamp halves must not be in contact)!

Aufbaumontage

RSB-Schellen erlauben die Montage mehrerer Schellen gleicher Baugröße, auch unterschiedlicher Rohrdurchmesser übereinander. Die Aufbaumontage erfolgt durch spezielle Aufbauschrauben, die durch Sicherungsplatten gegen Verdrehen gesichert werden. Untere Schellenhälfte auf Anschweißplatte oder Tragschiene aufkleben, Rohr einlegen, obere Schellenhälfte aufsetzen und mit Aufbauschrauben festziehen. Die Aufbauschraube ragt über die obere Schellenhälfte hinaus. Durch Auflegen eines Sicherungsbleches wird ein Verdrehen der Aufbauschraube verhindert. Zweite Rohrschelle auf die Aufbauschrauben aufkleben u.s.w.

Stacking assembly

RSB-Clamps allow the assembly of multiple clamps of the same construction size and of different tube diameters one above the other. The construction assembly is carried out with special fixing screws that are secured against twisting by applying a locking plate. Clamp lower clamp half on welding plate or mounting rail respectively, insert tube, place upper clamp half on lower half and fasten with fixing screws. The fixing screw juts out from the upper clamp half. The application of a locking plate securely fastens the fixing screw and prevents twisting. Clamp on second clamp half on to the fixing screws etc.

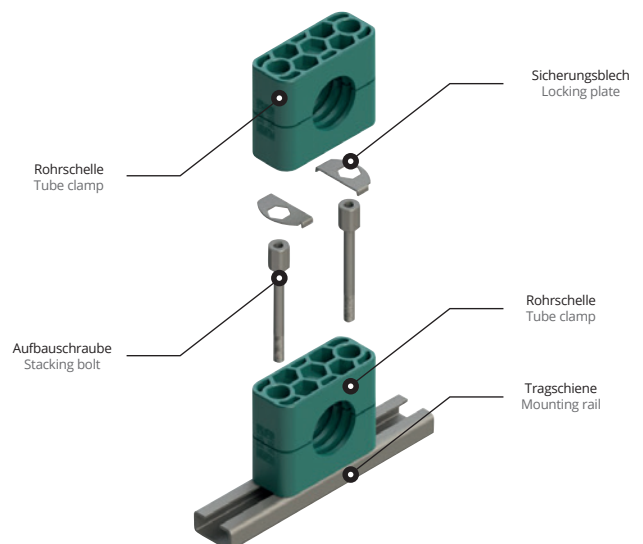

// SCHRAUBENZUGSMOMENTE UND AXIALE ROHRHALTEKRÄFTE // SCREW TIGHTENING TORQUE AND AXIAL PIPE SHEARING FORCES

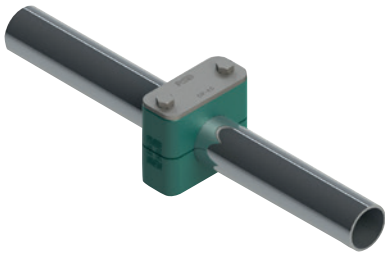

Die angegebenen Schraubenanzugsmomente und axialen Rohthaltekräfte beziehen sich auf Montage mit Anschweißplatten, Deckplatten und Außensechskantschrauben nach ISO 4014/4017 (DIN 931/933). Die axiale Rohthaltekraft (gemäß DIN 3015 Teil 10) ist ein Mittelwert, ermittelt aus drei Versuchen bei 23°C mit einem Stahlrohr nach DIN 2448 aus St 37, bei dem Haftreibung vorausgesetzt wird. Bei Belastung der RSB-Schelle in axialer Rohrrichtung mit der angegebenen Prüfkraft (F) gleitet das Rohr in der Schelle nicht.

The indicated screw tightening torque and axial pipe shearing forces refer to the assembly with weld plates, cover plates and hexagon head bolts according to ISO 4014/4017 (DIN 931/933). The axial pipe shearing force (according to DIN 3015, part 10) is an average value, determined by three tests made with a steel pipe according to DIN 2448 of St 37, for which static friction is presupposed (temperature during tests: 23°C). When loading the RSB clamp with the indicated test force (F) in axial pipe direction, the pipe does not slide in the clamp.

Leichte Baureihe (DIN 3015, Teil 1) / Light series (DIN 3015, part 1)

GRÖSSE SIZE	Befestigungs- schraube Fixing screw ISO 4014/4017 (DIN 931/933)	Polypropylen / Polypropylene		Polyamid / Polyamide		Aluminium / Aluminium	
		Schraubenanzugs- moment (Nm) Screw tightening torque (Nm)	Rohrhaltekraft F (kN) Pipe shearing force F (kN)	Schraubenanzugs- moment (Nm) Screw tightening torque (Nm)	Rohrhaltekraft F (kN) Pipe shearing force F (kN)	Schraubenanzugs- moment (Nm) Screw tightening torque (Nm)	Rohrhaltekraft F (kN) Pipe shearing force F (kN)
0	M 6	8	0,6	10	0,6		
1		8	1,1	10	0,7	12	4,2
2		8	1,2	10	0,8	12	4,3
3		8	1,4	10	1,6	12	4,8
4		8	1,5	10	1,7	12	5,0
5		8	1,9	10	2,0	12	7,3
6		8	2,0	10	2,5	12	8,9

Schwere Baureihe (DIN 3015, Teil 2) / Heavy series (DIN 3015, part 2)

GRÖSSE SIZE	Befestigungs- schraube Fixing screw ISO 4014/4017 (DIN 931/933)	Polypropylen / Polypropylene		Polyamid / Polyamide		Aluminium / Aluminium	
		Schraubenanzugs- moment (Nm) Screw tightening torque (Nm)	Rohrhaltekraft F (kN) Pipe shearing force F (kN)	Schraubenanzugs- moment (Nm) Screw tightening torque (Nm)	Rohrhaltekraft F (kN) Pipe shearing force F (kN)	Schraubenanzugs- moment (Nm) Screw tightening torque (Nm)	Rohrhaltekraft F (kN) Pipe shearing force F (kN)
1	M 10	12	1,6	20	4,2	30	12,1
2		12	2,9	20	4,5	30	15,1
3		15	3,3	25	5,1	35	15,5
4	M 12	30	8,2	40	9,3	55	29,4
5	M 16	45	11,0	55	15,8	120	34,8
6	M 20	80	14,0	150	21,0	220	50,0
7	M 24	110	28,0	200	32,0	250	70,6
8	M 30	180	40,0	350	48,0	500	84,5
9		200	119,0	370	125,0	500	181,5
10		270	168,0	450	180,0	600	244,5

Doppel-Baureihe (DIN 3015, Teil 3) / Double series (DIN 3015, part 3)

GRÖSSE SIZE	Befestigungs- schraube Fixing screw ISO 4014/4017 (DIN 931/933)	Polypropylen / Polypropylene		Polyamid / Polyamide	
		Schraubenanzugs- moment (Nm) Screw tightening torque (Nm)	Rohrhaltekraft F (kN) Pipe shearing force F (kN)	Schraubenanzugs- moment (Nm) Screw tightening torque (Nm)	Rohrhaltekraft F (kN) Pipe shearing force F (kN)
1	M 6	5	0,9	6	0,9
2	M 8	12	2,1	12	2,2
3		12	1,9	12	2,0
4		12	2,7	12	2,9
5		8	1,7	8	2,5

// EMPFOHLENER SCHELLENABSTAND

// RECOMMENDED CLAMP PITCH

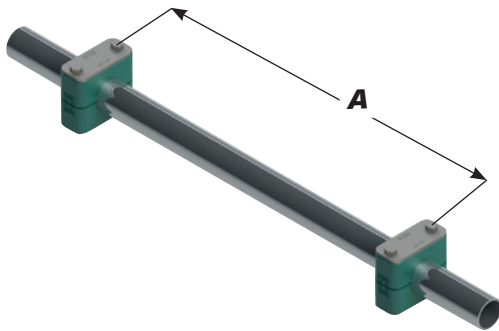

Die den entsprechenden Rohraußendurchmessern zugeordneten Schellenabstände sind Richtwerte für statische Belastung.

The clamp pitches assigned to the respective outside pipe diameters are standard values for static load.

Rohraußendurchmesser (mm) Outside pipe diameter (mm)	Schellenabstand A (m) Clamp pitch A (m)
6,0 - 12,7	1,0
12,7 - 22,0	1,2
22,0 - 32,0	1,5
32,0 - 38,0	2,0
38,0 - 57,0	2,7
57,0 - 75,0	3,0
75,0 - 76,1	3,5
76,1 - 88,9	3,7
88,9 - 102,0	4,0
102,0 - 114,0	4,5
114,0 - 168,0	5,0
168,0 - 219,0	6,0
219,0 - 324,0	6,7
324,0 - 356,0	7,0
356,0 - 406,0	7,5

// ROHRBOGENMONTAGE

// PIPE BEND ASSEMBLY



Rohrbögen sind unmittelbar vor und hinter dem Bogen mit RSB-Rohrschellen zu befestigen.

Pipe bends must be fixed with RSB-pipe clamps immediately in front of and behind the bend.

// 02

ROHRSCHELLEN SERIE A

TUBE CLAMPS SERIES A

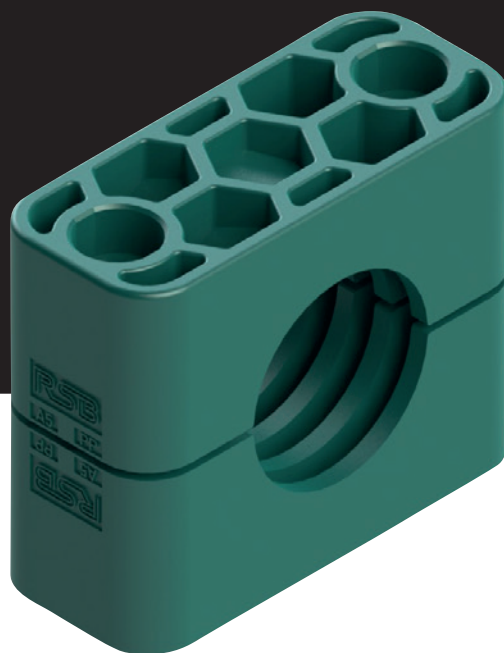

// ABMESSUNGEN UND GEWICHTE VON KOMPLETTSCHELLEN (MM)

// DIMENSIONS AND WEIGHTS OF TUBE CLAMPS, COMPLETE (MM)

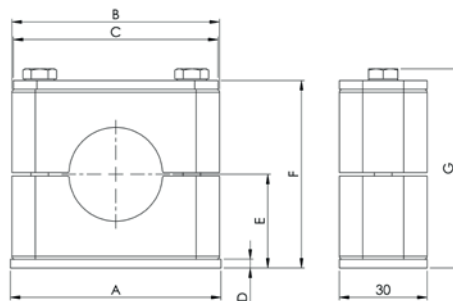

GRÖSSE SIZE	A	B	C	D	E		F		G		GEWICHT / 10 STK. WEIGHT / 10 PCS. RAPR3-xxx (kg)
					Rippen Grooved	Glatt Smooth	Rippen Grooved	Glatt Smooth	Rippen Grooved	Glatt Smooth	
0	30	28	28	3	16,5	16,2	33	32,4	37	36,4	0,66
1	36	34	34	3	16,5	16,2	33	32,4	37	36,4	0,82
2	42	42	40	3	19,5	19,1	39	38,2	43	42,2	0,98
3	50	49	48	3	20,5	20	41	40	45	44	1,14
4	59	59	57	3	24	23,4	48	46,8	52	50,8	1,36
5	72	71	70	3	32	31,4	64	62,8	68	66,8	1,83
6	88	86	86	3	36	35,4	72	70,8	76	74,8	2,22
7	122	121	120	5	51,8	51	103,6	102	107,6	106	4,55
8	148	147	146	5	63,8	63	127,6	126	131,6	130	6,18

Das Gewicht wurde mit dem kleinsten Durchmesser (siehe Katalog) und der Standard-Ausführung der Stahlteile der jeweiligen Größe in losen Zustand ermittelt.
The weight was determined with the smallest diameter (see catalogue) and the standard model of the steel parts of the respective quantity in bulk.



DIE LÖSUNG FÜR KORROSIONSGEFÄHRDETE ANWENDUNGEN

**THE SOLUTION
FOR SUSCEPTIBLE TO CORROSION APPLICATIONS**

PP-CR®



Auf Grundlage des bewährten Polypropylens wurde das PP-CR entwickelt.

Ein spezieller Korrosions-Inhibitor verzögert effektiv die Bildung von Spaltkorrosion zwischen den Schellenkörpern und der Verrohrung.

Diese korrosionsverzögerten Eigenschaften wurden in Salzsprühnebeltests gemäß DIN EN ISO 9227 getestet und nachgewiesen.

Rohrschellen aus PP-CR sind in allen Standardbaugrößen unseres bewährten RSB-Rohrschellensystems erhältlich.

Rohrschellen aus PP-CR sind in der Farbe schiefergrau verfügbar.

PP-CR has been developed based on our approved Polypropylene.

Crevice corrosion between the clamp halves and the tube is effectively retarded by a special corrosion inhibitor.

These properties have been tested and successfully approved in a salt spray test according to DIN EN ISO 9227.

Tube Clamps made of PP-CR are available in all standard dimensions of our approved RSB-TUBE CLAMP range.

Tube Clamps made of PP-CR are available in slate gray colour.



DER KORROSIONSHEMMER – ROHRSCHELLEN AUS PP-CR®

THE CORROSION INHIBITOR – TUBE CLAMPS MADE OF PP-CR®

Schellengröße clamp size	Rohr-AD mm O.D. mm d ₁	1 Stück / 2 Schellenhälften 1 part / 2 clamp-halves RAPG
1	4	RAPG-104/CR
	6	RAPG-106/CR
	6,4	RAPG-106,4/CR
	8	RAPG-108/CR
	9,5	RAPG-109,5/CR
	10	RAPG-110/CR
	12	RAPG-112/CR
	12,7	RAPG-112,7/CR
2	12,7	RAPG-212,7/CR
	13,5	RAPG-213,5/CR
	14	RAPG-214/CR
	15	RAPG-215/CR
	16	RAPG-216/CR
	17,2	RAPG-217,2/CR
3	18	RAPG-218/CR
	19	RAPG-319/CR
	20	RAPG-320/CR
	21,3	RAPG-321,3/CR
	22	RAPG-322/CR
	23	RAPG-323/CR
	25	RAPG-325/CR
25,4	RAPG-325,4/CR	
4	26,9	RAPG-426,9/CR
	28	RAPG-428/CR
	30	RAPG-430/CR
5	32	RAPG-532/CR
	33,7	RAPG-533,7/CR
	35	RAPG-535/CR
	38	RAPG-538/CR
	40	RAPG-540/CR
	42	RAPG-542/CR
6	44,5	RAPG-644,5/CR
	45	RAPG-645/CR
	48	RAPG-648/CR
	50	RAPG-650/CR
	50,8	RAPG-650,8/CR
	52	RAPG-652/CR
	54	RAPG-654/CR
	55	RAPG-655/CR
57	RAPG-657/CR	
7	57,2	RAPG-757,2/CR
	60,3	RAPG-760,3/CR
	63,5	RAPG-763,5/CR
	70	RAPG-770/CR
	73	RAPG-773/CR
	76,1	RAPG-776,1/CR
	88,9	RAPG-888,9/CR
8	101,8	RAPG-8101,8/CR

EDELSTAHLROHR (1.4571)
NACH 4500 STD. SALZNEBELSPRÜHTEST
STAINLESS STEEL TUBE (316Ti)
AFTER 4500 H SALT SPRAY TEST

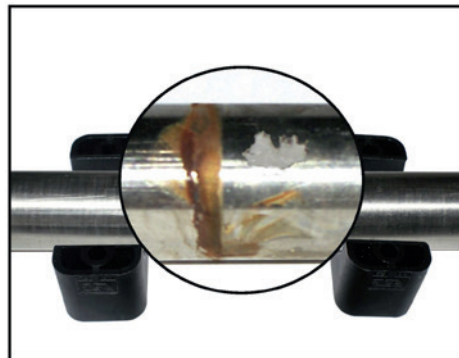

Resultat mit Standard-Polypropylene
Result with standard Polypropylene

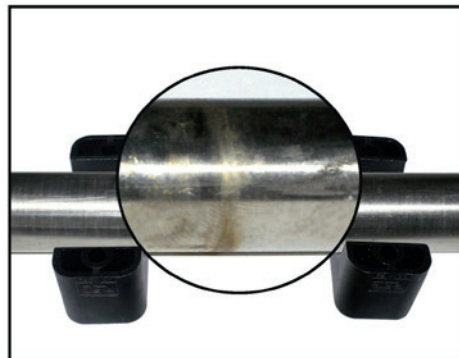

Resultat mit PP-CR
Result with PP-CR

Vorteile

- Enorme Reduzierung von Spaltkorrosion
- Verlängerung der Wartungsintervalle
- Kostenersparnis durch deutlich längere Lebensdauer der Rohrsysteme

Advantages

- Enormous reduction of crevice corrosion
- Extension of maintenance intervals
- cost reduction due to extended durability of the tubing

Bestellzeichen für Schellenhälften:

Polypropylen **RAPR**
 innen glatt **RAPG²⁾**
 Polyamid 6 **RANR**
 innen glatt **RANG²⁾**
 Vollgummi **RAVR^{3) 4)}**
RAVG^{2) 3)}
 Aluminium **RAAR¹⁾**

Bei Bedarf Standardkurzzeichen RAPR in der Spalte „Schellenhälften“ austauschen.

Order codes for clamp-halves:

Polypropylene **RAPR**
 inside smooth **RAPG²⁾**
 Polyamide 6 **RANR**
 inside smooth **RANG²⁾**
 Rubber **RAVR^{3) 4)}**
RAVG^{2) 3)}
 Aluminium **RAAR¹⁾**

Replace standard abbreviation RAPR in column "clamp-halves" as required.

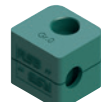

Größe 0
Size 0

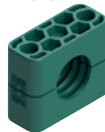

Größe 1-8
Size 1-8

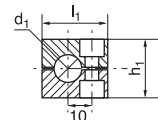

Größe 0
Size 0

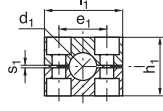

Größe 1-8
Size 1-8

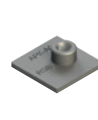

Größe 0
Size 0



Größe 1-8
Size 1-8

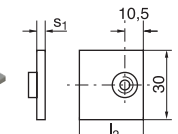

Größe 0
Size 0

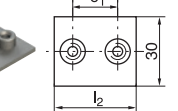

Größe 1-8
Size 1-8

GRÖSSE SIZE	Rohr-AD mm O.D. mm	Rohr-NW Tube NB	Rohr-AD Zoll Inch O.D.	RAPR 1 Stück / 2 Schellenhälften 1 part / 2 clamp-halves	RAPR-... 2 Schellenhälften 2 clamp-halves				APK-A Anschweißplatte Weld plate			
	d ₁				l ₁	h ₁	e ₁	s ₁	e ₁	l ₂	s ₁	
0	4	G 1/8	1/4	RAPR-004 RAPR-006 RAPR-006,4 RAPR-008 RAPR-009,5 RAPR-010 RAPR-012	28	27	-	0,6	APK-A 0	-	30	3
	6											
	6,4											
	8											
	9,5											
	10											
12												
1	4	G 1/8	1/4	RAPR-104 RAPR-106 RAPR-106,4 RAPR-108 RAPR-109,5 RAPR-110 RAPR-112	34	27	20	0,6	APK-A 1	20	36	3
	6											
	6,4											
	8											
	9,5											
	10											
12												
2	12,7	G 1/4	1/2	RAPR-212,7 RAPR-213,5 RAPR-214 RAPR-215 RAPR-216 RAPR-217,2 RAPR-218	42	33	26	0,8	APK-A 2	26	42	3
	13,5											
	14	G 3/8	5/8	RAPR-319 RAPR-320 RAPR-321,3 RAPR-322 RAPR-323 RAPR-325 RAPR-325,4	49	35	33	1	APK-A 3	33	50	3
	15											
	16											
	17,2											
18												
3	19	G 1/2	3/4	RAPR-426,9 RAPR-428 RAPR-430	59	42	40	1,2	APK-A 4	40	59	3
	20											
	21,3											
	22											
4	26,9	G 3/4	1	RAPR-532 RAPR-533,7 RAPR-535 RAPR-538 RAPR-540 RAPR-542	71	58	52	1,2	APK-A 5	52	72	3
	28											
	30											
	32											
	33,7											
	35											
38												
40												
42												
5	44,5	G 1 1/4	1 1/4	RAPR-644,5 RAPR-645 RAPR-648 RAPR-650 RAPR-650,8 RAPR-652 RAPR-654 RAPR-655 RAPR-657	86	66	66	1,2	APK-A 6	66	88	3
	45											
	48											
	50											
	50,8											
	52											
	54											
	55											
	57											
	6											
60,3												
63,5												
70												
73												
76,1												
7	88,9	G 2 1/2	3	RAPR-888,9 RAPR-8101,8	147	117,6	120	1,6	APK-A 8	120	148	5
	101,8											
8	88,9	G 3	3 1/2	RAPR-888,9 RAPR-8101,8	147	117,6	120	1,6	APK-A 8	120	148	5
	101,8											
8	88,9	G 3 1/2	4	RAPR-888,9 RAPR-8101,8	147	117,6	120	1,6	APK-A 8	120	148	5
	101,8											

Metallteile auch in Edelstahl lieferbar. ¹⁾Aluminium in Größen 0 bis 6 ²⁾ohne Vorspannung ³⁾Bei Montage von Vollgummi-Schellen sind Deckplatten, Sechskantschrauben und Sicherungsscheiben zu verwenden ⁴⁾Vollgummi in Größen 1 bis 5
 All metal parts available in stainless steel. ¹⁾Aluminium in sizes 0 to 6 ²⁾without prestress ³⁾When assembling solid rubber tube clamps, cover plates, hexagon screws and locking washers must be used ⁴⁾Rubber in sizes 1 to 5



ROHRSCHELLEN SERIE A | DIN 3015, TEIL 1 | EINZELTEILE
TUBE CLAMPS SERIES A | DIN 3015, PART 1 | COMPONENTS

Komplett-Programm siehe Seiten 21 bis 25. Complete range please refer to pages 21 to 25.

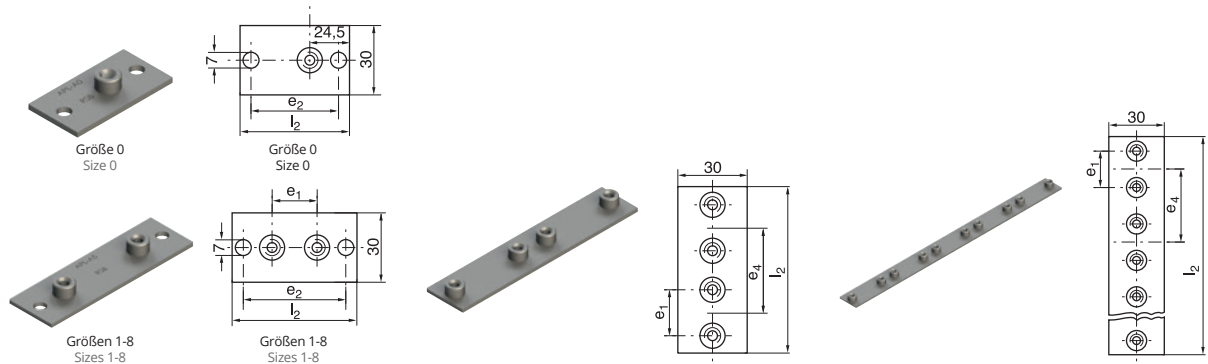

GRÖSSE SIZE	APL-A Anschweiß- und Schraubplatte, lang Weld- and screwplate, elongated			APD-A Anschweißplatte, doppelt Weldplate, double			APR-A Reihen-Anschweißplatte Multiple weld plate					
		e ₁	l ₂	e ₂		e ₁	e ₄	l ₂		e ₁	e ₄	l ₂
0	APL-A 0	-	58	44	APD-A 0	-	30	61	APR-A 0 10 Schellen / Clamps	-	30	298
1	APL-A 1	20	64	50	APD-A 1 APDL-A 1	20 20	35 40	69 76	APR-A 1 APRL-A 1 10 Schellen / Clamps	20 20	35 40	349 394
2	APL-A 2	26	70	56	APD-A 2 APDL-A 2	26 26	43 52	86 94	APR-A 2 APRL-A 2 10 Schellen / Clamps	26 26	43 52	427 508
3	APL-A 3	33	78	64	APD-A 3 APDL-A 3	33 33	52 75	104 125	APR-A 3 APRL-A 3 10 Schellen / Clamps	33 33	52 75	516 723
4	APL-A 4	40	87	73	APD-A 4	40	60	117	APR-A 4 5 Schellen / Clamps	40	60	297
5	APL-A 5	52	100	86	APD-A 5	52	75	145	APR-A 5 5 Schellen / Clamps	52	75	370
6	APL-A 6	66	116	100	APD-A 6	66	90	176	APR-A 6 5 Schellen / Clamps	66	90	446
7	APL-A 7	94	150	136								
8	APL-A 8	120	178	162								

Metallteile auch in Edelstahl lieferbar.
 All metal parts available in stainless steel.



ROHRSCHELLEN SERIE A (LEICHTBAUREIHE) | DIN 3015, TEIL 1 | EINZELTEILE
TUBE CLAMPS SERIES A (LIGHT CONSTRUCTION SERIES) | DIN 3015, PART 1 | COMPONENTS

Komplett-Programm siehe Seiten 21 bis 25. Complete range please refer to pages 21 to 25.

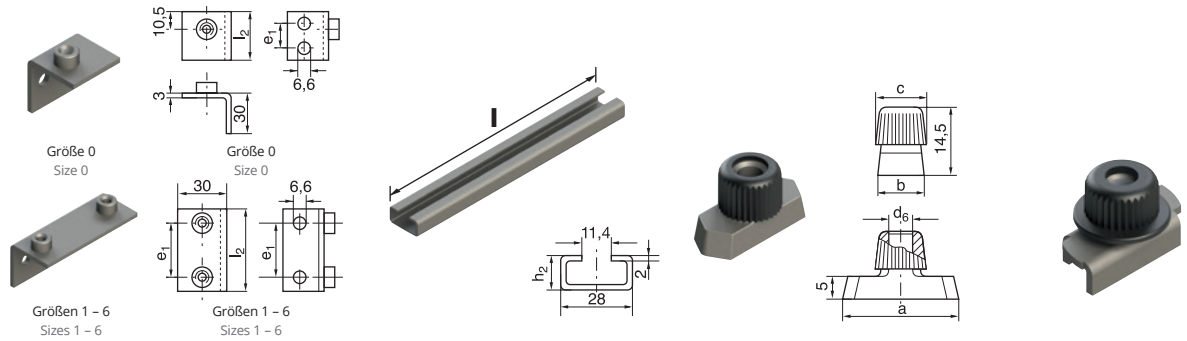

GRÖSSE SIZE	APW-A Winkel-Anschweißplatte Weld plate, angled		TS-A/B Tragschiene Mounting rail			TM-A/B 1 Tragschienen-Mutter Rail nut				TM-A/B 1 Visitec Visitec					
		e ₁	l ₂		l	h ₂	a	b	c	d ₆	a	b	c	d ₆	
0	APW-A 0	14	30												
1	APW-A 1	20	36												
2	APW-A 2	26	42												
3	APW-A 3	33	50	TS 11-A/B 1	1 m	11									
				TS 11-A/B 2	2 m	11									
4	APW-A 4	40	59	TS 14-A/B 1	1 m	14	TM-A (TM-B1)	25,4	10,4	12	M 6	24,9	10,5	12	M6
				TS 14-A/B 2	2 m	14									
5	APW-A 5	52	72	TS 30-A/B 1	1 m	30									
				TS 30-A/B 2	2 m	30									
6	APW-A 6	66	88												
7															
8															

Metallteile auch in Edelstahl lieferbar.
 All metal parts available in stainless steel.



ROHRSCHELLEN SERIE A (LEICHTBAUREIHE) | DIN 3015, TEIL 1 | EINZELTEILE
TUBE CLAMPS SERIES A (LIGHT CONSTRUCTION SERIES) | DIN 3015, PART 1 | COMPONENTS

Komplett-Programm siehe Seiten 21 bis 25. Complete range please refer to pages 21 to 25.

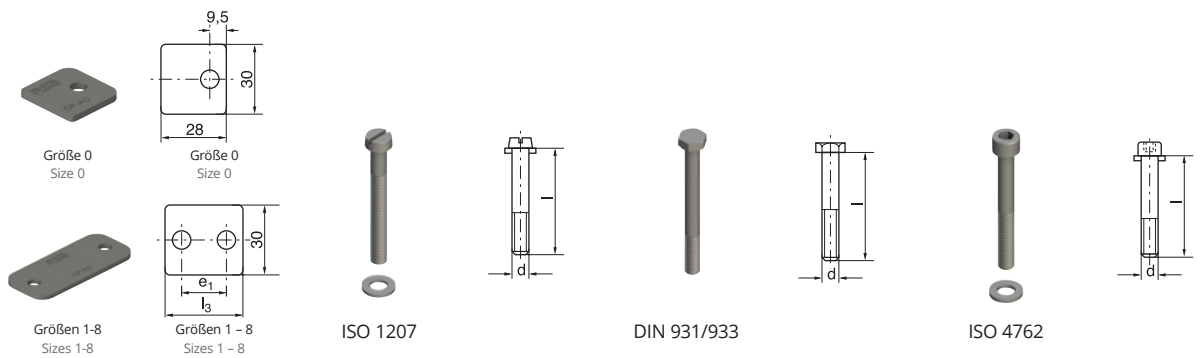

GRÖSSE SIZE	DP-A Deckplatte Cover plate		SL-A Schlitzschraube Slotted head screw		SSL-A Sechskantschraube Hexagon head screw		IS-A Innensechskantschraube Hexagon socket head screw								
	l_3	e_1	d	x	d	x	d	x							
0	DP-A 0	-	-	SL-A 0 / A 1	M 6	x	20	SSL-A 0 / A 1	M 6	x	30	IS-A 0 / A 1	M 6	x	20
1	DP-A 1	34	20	SL-A 0 / A 1	M 6	x	20	SSL-A 0 / A 1	M 6	x	30	IS-A 0 / A 1	M 6	x	20
2	DP-A 2	40	26	SL-A 2	M 6	x	25	SSL-A 2 (SS-B 1)	M 6	x	35	IS-A 2	M 6	x	25
3	DP-A 3	48	33	SL-A 3	M 6	x	30	SSL-A 3	M 6	x	40	IS-A 3	M 6	x	30
4	DP-A 4	57	40	SL-A 4	M 6	x	35	SSL-A 4	M 6	x	45	IS-A 4 (IS-B 1)	M 6	x	35
5	DP-A 5	70	52	SL-A 5	M 6	x	50	SSL-A 5	M 6	x	60	IS-A 5	M 6	x	50
6	DP-A 6	86	66	SL-A 6	M 6	x	60	SSL-A 6	M 6	x	70	IS-A 6	M 6	x	60
7	DP-A 7	120	94	SL-A 7 ¹⁾	M 6	x	90	SSL-A 7	M 6	x	100	IS-A 7	M 6	x	90
8	DP-A 8	146	120	SL-A 8 ¹⁾	M 6	x	110	SSL-A 8 ¹⁾	M 6	x	125	IS-A 8	M 6	x	110

Metallteile auch in Edelstahl lieferbar.

¹⁾ Länge nicht handelsüblich - evtl. längere Lieferzeit

All metal parts available in stainless steel.

¹⁾ length not commercially available - extended lead time may occur



Komplett-Programm siehe Seiten 21 bis 25. Complete range please refer to pages 21 to 25.

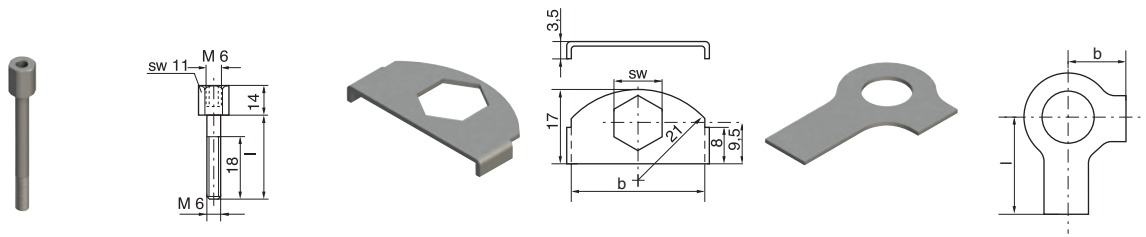

GRÖSSE SIZE	AS-A Aufbauschraube ¹⁾ Stacking bolt ¹⁾		SBR-A Sicherungsblech ¹⁾ Locking plate ¹⁾			US-A Sicherungscheibe ²⁾ Locking washer ²⁾		
		l		b	SW		b	l
0	AS-A 0 / A 1 (AS-B1)	20						
1	AS-A 0 / A 1 (AS-B1)	20						
2	AS-A 2	25						
3	AS-A 3	28						
4	AS-A 4	34	SBR-A	30	11	US-A	9	18
5	AS-A 5	50						
6	AS-A 6	60						
7	AS-A 7	85						
8	AS-A 8	110						

Metallteile auch in Edelstahl lieferbar.

¹⁾Für Einsatz von Aufbauschrauben bei Aufbaumontage sind Sicherungsbleche notwendig

²⁾Bei Montage von Vollgummi-Schellen sind Deckplatten, Sechskantschrauben und Sicherungscheiben zu verwenden

All metal parts available in stainless steel.

¹⁾The usage of stacking bolts necessitates the use of locking plates during the construction assembly

²⁾When assembling solid rubber clamps, cover plates, hexagon screws and locking washers must be used



DIE SCHIENENMUTTER MIT VERLUSTSICHERUNG

THE RAILNUT WITH LOSS PROTECTION

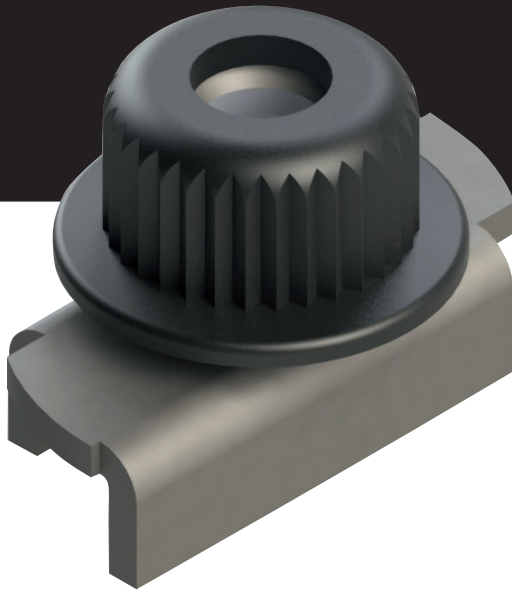

LEICHTE BAUREIHE

Bestellbezeichnung:

TM-A/B1 VISITEC 1.4571

TM-A/B1 VISITEC ZN

Lieferbar in verzinkter Ausführung und Edelstahl 1.4571.

LIGHT SERIES

Order Code:

TM-A/B1 VISITEC 1.4571

TM-A/B1 VISITEC ZN

Available in zinc plated version and in stainless steel 1.4571

VORTEILE

- 40 % Zeitersparnis bei der Montage
- Schnelle und einfache Installation
- Schall- und vibrationsdämmend
- Optimal bei vertikaler Montage

ADVANTAGES

- 40% time savings during installation
- Fast and easy to install
- Vibration and sound insulating function
- Especially for vertical installations

Das neue Design verhindert den Verlust der Gummikappe während der Installation. Der große Gummiflansch verhindert dass die Tragschienenmutter während der Montage in die Schiene fällt und hat zusätzlich eine schall- und vibrationsdämmende Funktion.

Die Gummikappe verfügt über eine integrierte Schraubensicherung.

Schnelle und einfache Installation, einfach zu justieren auch bei vertikalen Installationen.

The big flange prevents that the railnut falls into the rail during installation and has a vibration and sound insulating function.

The rubbercap has an integrated screw locking device. Fast and easy to install, easy to adjust, especially for vertical installations.

Bestellzeichen

für Schellenhälften:

Polypropylen **RAPS-540**
 Polyamid 6 **RANS-540**
 Vollgummi **RAVS-540**

Order codes

for clamp-halves:

Polypropylene **RAPS-540**
 Polyamide 6 **RANS-540**
 Rubber **RAVS-540**

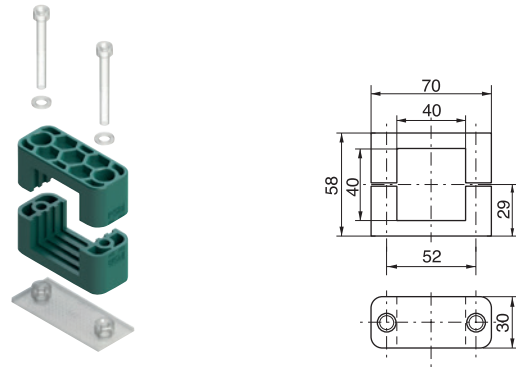

1 Stück = 2 Schellenhälften
 1 piece = 2 clamp halves

Befestigungsschelle für Näherungsschalter nach EN 50 025 und 50 037 mit quadratischem Gehäuse 40 x 40 mm. Bei Montage auf Tragschienen können die Sensoren in axialer und seitlicher Richtung eingestellt werden. Montagezubehör entsprechend Serie A, Größe 5.

Fixing clamp for proximity switch built to EN 50 025 and 50 037 with square casing 40 x 40 mm. The sensors can be adjusted axially and laterally when mounted on mounting rails. Accessory materials same as in Series A, size 5.



Für die Befestigung von Näherungsschalter mit zylindrischem Gehäuse nach EN 50 008, 50 036 und 50 040 oder ähnliche können Rohrschellen der Serie A mit entsprechendem Durchmesser verwendet werden.

Series A tube clamps of suitable diameter can be used for fixing proximity switches with a cylindrical casing built according to EN 50 008, 50 036 and 50 040 or similar.

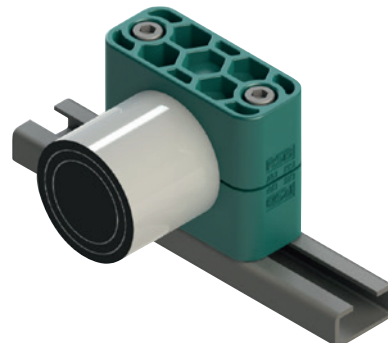

ROHRSCHELLEN SERIE A | KOMPLETT-PROGRAMM TUBE CLAMPS SERIES A | COMPLETE RANGE

Bestellzeichen für Schellenhälften:

Polypropylen
innen glatt
Polyamid 6
innen glatt
Vollgummi

Aluminium

RAPR
RAPG
RANR
RANG
RAVR^{3) 4)}
RAVG³⁾
RAAR²⁾

Bei Bedarf Standardkurzzeichen RAPR in der Spalte „Bestellzeichen“ austauschen.

Order codes for clamp halves:

Polypropylene
inside smooth
Polyamide 6
inside smooth
Rubber

Aluminium

RAPR
RAPG
RANR
RANG
RAVR^{3) 4)}
RAVG³⁾
RAAR²⁾

Replace standard abbreviation RAPR in column "Order codes" as required.

2 Schellenhälften mit
Anschweißplatte,
Schlitzschrauben und
U-Scheiben
2 clamp halves with weld plate,
slotted head screws and washer



2 Schellenhälften mit
Anschweißplatte,
Innensechskantschrauben und
U-Scheiben
2 clamp halves with weld plate, hexa-
gon socket head screws and washer



2 Schellenhälften mit
Anschweißplatte,
Deckplatte und Sechskantschrauben
2 clamp halves with weld plate, cover
plate and hexagon head screws



GRÖSSE SIZE	Rohr-AD mm O.D. mm	Rohr-NW Tube NB	Rohr-AD Zoll Inch O.D.	Bestellzeichen Order Codes	Bestellzeichen Order Codes	Bestellzeichen Order Codes
0 ¹⁾	4 6 6,4 8 9,5 10 12	G 1/8	1/4 5/16 3/8	RAPR 1-004 RAPR 1-006 RAPR 1-006,4 RAPR 1-008 RAPR 1-009,5 RAPR 1-010 RAPR 1-012	RAPR 2-004 RAPR 2-006 RAPR 2-006,4 RAPR 2-008 RAPR 2-009,5 RAPR 2-010 RAPR 2-012	RAPR 3-004 RAPR 3-006 RAPR 3-006,4 RAPR 3-008 RAPR 3-009,5 RAPR 3-010 RAPR 3-012
1	4 6 6,4 8 9,5 10 12	G 1/8	1/4 5/16 3/8	RAPR 1-104 RAPR 1-106 RAPR 1-106,4 RAPR 1-108 RAPR 1-109,5 RAPR 1-110 RAPR 1-112	RAPR 2-104 RAPR 2-106 RAPR 2-106,4 RAPR 2-108 RAPR 2-109,5 RAPR 2-110 RAPR 2-112	RAPR 3-104 RAPR 3-106 RAPR 3-106,4 RAPR 3-108 RAPR 3-109,5 RAPR 3-110 RAPR 3-112
2	12,7 13,5 14 15 16 17,2 18	G 1/4 G 3/8	1/2 5/8	RAPR 1-212,7 RAPR 1-213,5 RAPR 1-214 RAPR 1-215 RAPR 1-216 RAPR 1-217,2 RAPR 1-218	RAPR 2-212,7 RAPR 2-213,5 RAPR 2-214 RAPR 2-215 RAPR 2-216 RAPR 2-217,2 RAPR 2-218	RAPR 3-212,7 RAPR 3-213,5 RAPR 3-214 RAPR 3-215 RAPR 3-216 RAPR 3-217,2 RAPR 3-218
3	19 20 21,3 22 23 25 25,4	G 1/2	3/4 1	RAPR 1-319 RAPR 1-320 RAPR 1-321,3 RAPR 1-322 RAPR 1-323 RAPR 1-325 RAPR 1-325,4	RAPR 2-319 RAPR 2-320 RAPR 2-321,3 RAPR 2-322 RAPR 2-323 RAPR 2-325 RAPR 2-325,4	RAPR 3-319 RAPR 3-320 RAPR 3-321,3 RAPR 3-322 RAPR 3-323 RAPR 3-325 RAPR 3-325,4
4	26,9 28 30	G 3/4		RAPR 1-426,9 RAPR 1-428 RAPR 1-430	RAPR 2-426,9 RAPR 2-428 RAPR 2-430	RAPR 3-426,9 RAPR 3-428 RAPR 3-430
5	32 33,7 35 38 40 42	G 1 G 1 1/4	1 1/4 1 1/2	RAPR 1-532 RAPR 1-533,7 RAPR 1-535 RAPR 1-538 RAPR 1-540 RAPR 1-542	RAPR 2-532 RAPR 2-533,7 RAPR 2-535 RAPR 2-538 RAPR 2-540 RAPR 2-542	RAPR 3-532 RAPR 3-533,7 RAPR 3-535 RAPR 3-538 RAPR 3-540 RAPR 3-542
6	44,5 45 48 50 50,8 52 54 55 57	G 1 1/2	1 3/4 2	RAPR 1-644,5 RAPR 1-645 RAPR 1-648 RAPR 1-650 RAPR 1-650,8 RAPR 1-652 RAPR 1-654 RAPR 1-655 RAPR 1-657	RAPR 2-644,5 RAPR 2-645 RAPR 2-648 RAPR 2-650 RAPR 2-650,8 RAPR 2-652 RAPR 2-654 RAPR 2-655 RAPR 2-657	RAPR 3-644,5 RAPR 3-645 RAPR 3-648 RAPR 3-650 RAPR 3-650,8 RAPR 3-652 RAPR 3-654 RAPR 3-655 RAPR 3-657
7	57,2 60,3 63,5 70 73 76,1	G 2 G 2 1/2	2 1/4 2 1/2 2 3/4 3	RAPR 1-757,2 RAPR 1-760,3 RAPR 1-763,5 RAPR 1-770 RAPR 1-773 RAPR 1-776,1	RAPR 2-757,2 RAPR 2-760,3 RAPR 2-763,5 RAPR 2-770 RAPR 2-773 RAPR 2-776,1	RAPR 3-757,2 RAPR 3-760,3 RAPR 3-763,5 RAPR 3-770 RAPR 3-773 RAPR 3-776,1
8	88,9 101,8	G 3 G 3 1/2	3 1/2 4	RAPR 1-888,9 RAPR 1-8101,8	RAPR 2-888,9 RAPR 2-8101,8	RAPR 3-888,9 RAPR 3-8101,8

Werden andere Kombinationen benötigt, so bestellen Sie diese bitte in Einzelteilen (Bestellzeichen hierfür siehe Seiten 14 – 18). Die Auslieferung erfolgt unmontiert in Einzelteilen. ¹⁾Schellen der Größe 0 werden in Abweichung von den Abbildungen nur mit einer Schraube befestigt ²⁾Aluminium in Größen 0 bis 6

³⁾Bei Montage von Vollgummi-Schellen sind Deckplatten, Sechskantschrauben und Sicherungsscheiben zu verwenden ⁴⁾Vollgummi in Größen 1 bis 5

If different combinations are required, we would be obliged if they could be ordered as separate components (Please refer to individual components, pages 14 – 18). Delivery in unassembled individual components. ¹⁾Contrary to illustration size 0 clamps are secured by only one screw ²⁾Aluminium in sizes 0 to 6

³⁾When assembling solid rubber tube clamps, cover plates, hexagon screws and locking washers must be used ⁴⁾Rubber in sizes 1 to 5

Bestellzeichen

für Schellenhälften:

Polypropylen **RAPR**
 innen glatt **RAPG**
 Polyamid 6 **RANR**
 innen glatt **RANG**
 Vollgummi **RAVR³⁾ 4)**
RAVG³⁾
 Aluminium **RAAR²⁾**

Bei Bedarf Standardkurzzeichen RAPR in der Spalte „Schellenhälften“ austauschen.

Order codes for clamp-halves:

Polypropylene **RAPR**
 inside smooth **RAPG**
 Polyamide 6 **RANR**
 inside smooth **RANG**
 Rubber **RAVR³⁾ 4)**
RAVG³⁾
 Aluminium **RAAR²⁾**

Replace standard abbreviation RAPR in column "clamp-halves" as required.

2 Schellenhälften mit Anschweiß-/Anschraubplatte, Schlitzschrauben und U-Scheiben
 2 clamp halves with weld/screw plate, slotted head screws and washer

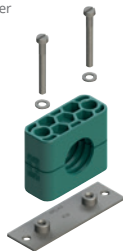

2 Schellenhälften mit Anschweiß-/Anschraubplatte, Innensechskantschrauben und U-Scheiben
 2 clamp halves with weld/screw plate, hexagon socket head screws and washer

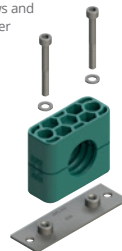

2 Schellenhälften mit Anschweiß-/Anschraubplatte, Deckplatte und Sechskantschrauben
 2 clamp halves with weld/screw plate, cover plate and hexagon head screws



GRÖSSE SIZE	Rohr-AD mm O.D. mm	Rohr-NW Tube NB	Rohr-AD Zoll Inch O.D.	Bestellzeichen Order Codes	Bestellzeichen Order Codes	Bestellzeichen Order Codes
0 ¹⁾	4 6 6,4 8 9,5 10 12	G 1/8	1/4 5/16 3/8	RAPR 4-004 RAPR 4-006 RAPR 4-006,4 RAPR 4-008 RAPR 4-009,5 RAPR 4-010 RAPR 4-012	RAPR 5-004 RAPR 5-006 RAPR 5-006,4 RAPR 5-008 RAPR 5-009,5 RAPR 5-010 RAPR 5-012	RAPR 6-004 RAPR 6-006 RAPR 6-006,4 RAPR 6-008 RAPR 6-009,5 RAPR 6-010 RAPR 6-012
1	4 6 6,4 8 9,5 10 12	G 1/8	1/4 5/16 3/8	RAPR 4-104 RAPR 4-106 RAPR 4-106,4 RAPR 4-108 RAPR 4-109,5 RAPR 4-110 RAPR 4-112	RAPR 5-104 RAPR 5-106 RAPR 5-106,4 RAPR 5-108 RAPR 5-109,5 RAPR 5-110 RAPR 5-112	RAPR 6-104 RAPR 6-106 RAPR 6-106,4 RAPR 6-108 RAPR 6-109,5 RAPR 6-110 RAPR 6-112
2	12,7 13,5 14 15 16 17,2 18	G 1/4 G 3/8	1/2 5/8	RAPR 4-212,7 RAPR 4-213,5 RAPR 4-214 RAPR 4-215 RAPR 4-216 RAPR 4-217,2 RAPR 4-218	RAPR 5-212,7 RAPR 5-213,5 RAPR 5-214 RAPR 5-215 RAPR 5-216 RAPR 5-217,2 RAPR 5-218	RAPR 6-212,7 RAPR 6-213,5 RAPR 6-214 RAPR 6-215 RAPR 6-216 RAPR 6-217,2 RAPR 6-218
3	19 20 21,3 22 23 25 25,4	G 1/2	3/4 1	RAPR 4-319 RAPR 4-320 RAPR 4-321,3 RAPR 4-322 RAPR 4-323 RAPR 4-325 RAPR 4-325,4	RAPR 5-319 RAPR 5-320 RAPR 5-321,3 RAPR 5-322 RAPR 5-323 RAPR 5-325 RAPR 5-325,4	RAPR 6-319 RAPR 6-320 RAPR 6-321,3 RAPR 6-322 RAPR 6-323 RAPR 6-325 RAPR 6-325,4
4	26,9 28 30	G 3/4		RAPR 4-426,9 RAPR 4-428 RAPR 4-430	RAPR 5-426,9 RAPR 5-428 RAPR 5-430	RAPR 6-426,9 RAPR 6-428 RAPR 6-430
5	32 33,7 35 38 40 42	G 1 G 1 1/4	1 1/4 1 1/2	RAPR 4-532 RAPR 4-533,7 RAPR 4-535 RAPR 4-538 RAPR 4-540 RAPR 4-542	RAPR 5-532 RAPR 5-533,7 RAPR 5-535 RAPR 5-538 RAPR 5-540 RAPR 5-542	RAPR 6-532 RAPR 6-533,7 RAPR 6-535 RAPR 6-538 RAPR 6-540 RAPR 6-542
6	44,5 45 48 50 50,8 52 54 55 57	G 1 1/2	1 3/4 2	RAPR 4-644,5 RAPR 4-645 RAPR 4-648 RAPR 4-650 RAPR 4-650,8 RAPR 4-652 RAPR 4-654 RAPR 4-655 RAPR 4-657	RAPR 5-644,5 RAPR 5-645 RAPR 5-648 RAPR 5-650 RAPR 5-650,8 RAPR 5-652 RAPR 5-654 RAPR 5-655 RAPR 5-657	RAPR 6-644,5 RAPR 6-645 RAPR 6-648 RAPR 6-650 RAPR 6-650,8 RAPR 6-652 RAPR 6-654 RAPR 6-655 RAPR 6-657
7	57,2 60,3 63,5 70 73 76,1	G 2 G 2 1/2	2 1/4 2 1/2 2 3/4 3	RAPR 4-757,2 RAPR 4-760,3 RAPR 4-763,5 RAPR 4-770 RAPR 4-773 RAPR 4-776,1	RAPR 5-757,2 RAPR 5-760,3 RAPR 5-763,5 RAPR 5-770 RAPR 5-773 RAPR 5-776,1	RAPR 6-757,2 RAPR 6-760,3 RAPR 6-763,5 RAPR 6-770 RAPR 6-773 RAPR 6-776,1
8	88,9 101,8	G 3 G 3 1/2	3 1/2 4	RAPR 4-888,9 RAPR 4-8101,8	RAPR 5-888,9 RAPR 5-8101,8	RAPR 6-888,9 RAPR 6-8101,8

Werden andere Kombinationen benötigt, so bestellen Sie diese bitte in Einzelteilen (Bestellzeichen hierfür siehe Seiten 14 – 18). Die Auslieferung erfolgt unmontiert in Einzelteilen. ¹⁾Schellen der Größe 0 werden in Abweichung von den Abbildungen nur mit einer Schraube befestigt ²⁾Aluminium in Größen 0 bis 6 ³⁾Bei Montage von Vollgummi-Schellen sind Deckplatten, Sechskantschrauben und Sicherungsscheiben zu verwenden ⁴⁾Vollgummi in Größen 1 bis 5
 If different combinations are required, we would be obliged if they could be ordered as separate components (Please refer to individual components, pages 14 – 18). Delivery in unassembled individual components. ¹⁾Contrary to illustration size 0 clamps are secured by only one screw ²⁾Aluminium in sizes 0 to 6 ³⁾When assembling solid rubber tube clamps, cover plates, hexagon screws and locking washers must be used ⁴⁾Rubber in sizes 1 to 5

ROHRSCHELLEN SERIE A | KOMPLETT-PROGRAMM

TUBE CLAMPS SERIES A | COMPLETE RANGE

Bestellzeichen

für Schellenhälften:

Polypropylen
innen glatt
Polyamid 6
innen glatt
Vollgummi

Aluminium

RAPR
RAPG
RANR
RANG
RAVR^{3) 4)}
RAVG³⁾
RAAR²⁾

Bei Bedarf Standardkurzzeichen RAPR in der Spalte „Bestellzeichen“ austauschen.

Order codes for clamp halves:

Polypropylene
inside smooth
Polyamide 6
inside smooth
Rubber

Aluminium

Replace standard abbreviation RAPR in column "Order codes" as required.

2 Schellenhälften mit Tragschienen-Muttern, Schlitzschrauben und U-Scheiben
2 clamp halves with rail nuts, slotted head screws and washer



2 Schellenhälften mit Tragschienen-Muttern, Innensechskantschrauben und U-Scheiben
2 clamp halves with rail nuts, socket head bolts and washer



2 Schellenhälften mit Tragschienen-Muttern, Deckplatte und Sechskantschrauben
2 clamp halves with rail nuts, cover plate and hexagon head screws



GRÖSSE SIZE	Rohr-AD mm O.D. mm	Rohr-NW Tube NB	Rohr-AD Zoll Inch O.D.	Bestellzeichen Order Codes	Bestellzeichen Order Codes	Bestellzeichen Order Codes
0 ¹⁾	4 6 6,4 8 9,5 10 12	G 1/8	1/4 5/16 3/8	RAPR 9-004 RAPR 9-006 RAPR 9-006,4 RAPR 9-008 RAPR 9-009,5 RAPR 9-010 RAPR 9-012	RAPR 10-004 RAPR 10-006 RAPR 10-006,4 RAPR 10-008 RAPR 10-009,5 RAPR 10-010 RAPR 10-012	RAPR 12-004 RAPR 12-006 RAPR 12-006,4 RAPR 12-008 RAPR 12-009,5 RAPR 12-010 RAPR 12-012
1	4 6 6,4 8 9,5 10 12	G 1/8	1/4 5/16 3/8	RAPR 9-104 RAPR 9-106 RAPR 9-106,4 RAPR 9-108 RAPR 9-109,5 RAPR 9-110 RAPR 9-112	RAPR 10-104 RAPR 10-106 RAPR 10-106,4 RAPR 10-108 RAPR 10-109,5 RAPR 10-110 RAPR 10-112	RAPR 12-104 RAPR 12-106 RAPR 12-106,4 RAPR 12-108 RAPR 12-109,5 RAPR 12-110 RAPR 12-112
2	12,7 13,5 14 15 16 17,2 18	G 1/4 G 3/8	1/2 5/8	RAPR 9-212,7 RAPR 9-213,5 RAPR 9-214 RAPR 9-215 RAPR 9-216 RAPR 9-217,2 RAPR 9-218	RAPR 10-212,7 RAPR 10-213,5 RAPR 10-214 RAPR 10-215 RAPR 10-216 RAPR 10-217,2 RAPR 10-218	RAPR 12-212,7 RAPR 12-213,5 RAPR 12-214 RAPR 12-215 RAPR 12-216 RAPR 12-217,2 RAPR 12-218
3	19 20 21,3 22 23 25 25,4	G 1/2	3/4 1	RAPR 9-319 RAPR 9-320 RAPR 9-321,3 RAPR 9-322 RAPR 9-323 RAPR 9-325 RAPR 9-325,4	RAPR 10-319 RAPR 10-320 RAPR 10-321,3 RAPR 10-322 RAPR 10-323 RAPR 10-325 RAPR 10-325,4	RAPR 12-319 RAPR 12-320 RAPR 12-321,3 RAPR 12-322 RAPR 12-323 RAPR 12-325 RAPR 12-325,4
4	26,9 28 30	G 3/4		RAPR 9-426,9 RAPR 9-428 RAPR 9-430	RAPR 10-426,9 RAPR 10-428 RAPR 10-430	RAPR 12-426,9 RAPR 12-428 RAPR 12-430
5	32 33,7 35 38 40 42	G 1 G 1 1/4	1 1/4 1 1/2	RAPR 9-532 RAPR 9-533,7 RAPR 9-535 RAPR 9-538 RAPR 9-540 RAPR 9-542	RAPR 10-532 RAPR 10-533,7 RAPR 10-535 RAPR 10-538 RAPR 10-540 RAPR 10-542	RAPR 12-532 RAPR 12-533,7 RAPR 12-535 RAPR 12-538 RAPR 12-540 RAPR 12-542
6	44,5 45 48 50 50,8 52 54 55 57	G 1 1/2	1 3/4 2	RAPR 9-644,5 RAPR 9-645 RAPR 9-648 RAPR 9-650 RAPR 9-650,8 RAPR 9-652 RAPR 9-654 RAPR 9-655 RAPR 9-657	RAPR 10-644,5 RAPR 10-645 RAPR 10-648 RAPR 10-650 RAPR 10-650,8 RAPR 10-652 RAPR 10-654 RAPR 10-655 RAPR 10-657	RAPR 12-644,5 RAPR 12-645 RAPR 12-648 RAPR 12-650 RAPR 12-650,8 RAPR 12-652 RAPR 12-654 RAPR 12-655 RAPR 12-657
7	57,2 60,3 63,5 70 73 76,1	G 2 G 2 1/2	2 1/4 2 1/2 2 3/4 3	RAPR 9-757,2 RAPR 9-760,3 RAPR 9-763,5 RAPR 9-770 RAPR 9-773 RAPR 9-776,1	RAPR 10-757,2 RAPR 10-760,3 RAPR 10-763,5 RAPR 10-770 RAPR 10-773 RAPR 10-776,1	RAPR 12-757,2 RAPR 12-760,3 RAPR 12-763,5 RAPR 12-770 RAPR 12-773 RAPR 12-776,1
8	88,9 101,8	G 3 G 3 1/2	3 1/2 4	RAPR 9-888,9 RAPR 9-8101,8	RAPR 10-888,9 RAPR 10-8101,8	RAPR 12-888,9 RAPR 12-8101,8

Werden andere Kombinationen benötigt, so bestellen Sie diese bitte in Einzelteilen (Bestellzeichen hierfür siehe Seiten 14 – 18). Die Auslieferung erfolgt unmontiert in Einzelteilen. ¹⁾Schellen der Größe 0 werden in Abweichung von den Abbildungen nur mit einer Schraube befestigt ²⁾Aluminium in Größen 0 bis 6

³⁾Bei Montage von Vollgummi-Schellen sind Deckplatten, Sechskantschrauben und Sicherungsscheiben zu verwenden ⁴⁾Vollgummi in Größen 1 bis 5

If different combinations are required, we would be obliged if they could be ordered as separate components (Please refer to individual components, pages 14 – 18). Delivery in unassembled individual components. ¹⁾Contrary to illustration size 0 clamps are secured by only one screw ²⁾Aluminium in sizes 0 to 6

³⁾When assembling solid rubber tube clamps, cover plates, hexagon screws and locking washers must be used ⁴⁾Rubber in sizes 1 to 5

Bestellzeichen

für Schellenhälften:

Polypropylen **RAPR**
 innen glatt **RAPG**
 Polyamid 6 **RANR**
 innen glatt **RANG**
 Vollgummi **RAVR³⁾**
RAVG³⁾
 Aluminium **RAAR²⁾**

Bei Bedarf Standardkurzzeichen RAPR in der Spalte „Schellenhälften“ austauschen.

Order codes

for clamp-halves:

Polypropylene **RAPR**
 inside smooth **RAPG**
 Polyamide 6 **RANR**
 inside smooth **RANG**
 Rubber **RAVR³⁾**
RAVG³⁾
 Aluminium **RAAR²⁾**

Replace standard abbreviation RAPR in column "clamp-halves" as required.

2 Schellenhälften mit Schlitzschrauben und U-Scheiben
 2 clamp halves, slotted head screws and washer



2 Schellenhälften mit Innensechskantschrauben und U-Scheiben
 2 clamp halves, hexagon socket head screws and washer



GRÖSSE SIZE	Rohr-AD mm O.D. mm	Rohr-NW Tube NB	Rohr-AD Zoll Inch O.D.	Bestellzeichen Order Codes	Bestellzeichen Order Codes
0 ¹⁾	4 6 6,4 8 9,5 10 12	G 1/8	1/4 5/16 3/8	RAPR 13-004 RAPR 13-006 RAPR 13-006,4 RAPR 13-008 RAPR 13-009,5 RAPR 13-010 RAPR 13-012	RAPR 14-004 RAPR 14-006 RAPR 14-006,4 RAPR 14-008 RAPR 14-009,5 RAPR 14-010 RAPR 14-012
1	4 6 6,4 8 9,5 10 12	G 1/8	1/4 5/16 3/8	RAPR 13-104 RAPR 13-106 RAPR 13-106,4 RAPR 13-108 RAPR 13-109,5 RAPR 13-110 RAPR 13-112	RAPR 14-104 RAPR 14-106 RAPR 14-106,4 RAPR 14-108 RAPR 14-109,5 RAPR 14-110 RAPR 14-112
2	12,7 13,5 14 15 16 17,2 18	G 1/4 G 3/8	1/2 5/8	RAPR 13-212,7 RAPR 13-213,5 RAPR 13-214 RAPR 13-215 RAPR 13-216 RAPR 13-217,2 RAPR 13-218	RAPR 14-212,7 RAPR 14-213,5 RAPR 14-214 RAPR 14-215 RAPR 14-216 RAPR 14-217,2 RAPR 14-218
3	19 20 21,3 22 23 25 25,4	G 1/2	3/4 1	RAPR 13-319 RAPR 13-320 RAPR 13-321,3 RAPR 13-322 RAPR 13-323 RAPR 13-325 RAPR 13-325,4	RAPR 14-319 RAPR 14-320 RAPR 14-321,3 RAPR 14-322 RAPR 14-323 RAPR 14-325 RAPR 14-325,4
4	26,9 28 30	G 3/4		RAPR 13-426,9 RAPR 13-428 RAPR 13-430	RAPR 14-426,9 RAPR 14-428 RAPR 14-430
5	32 33,7 35 38 40 42	G 1 G 1 1/4	1 1/4 1 1/2	RAPR 13-532 RAPR 13-533,7 RAPR 13-535 RAPR 13-538 RAPR 13-540 RAPR 13-542	RAPR 14-532 RAPR 14-533,7 RAPR 14-535 RAPR 14-538 RAPR 14-540 RAPR 14-542
6	44,5 45 48 50 50,8 52 54 55 57	G 1 1/2	1 3/4 2	RAPR 13-644,5 RAPR 13-645 RAPR 13-648 RAPR 13-650 RAPR 13-650,8 RAPR 13-652 RAPR 13-654 RAPR 13-655 RAPR 13-657	RAPR 14-644,5 RAPR 14-645 RAPR 14-648 RAPR 14-650 RAPR 14-650,8 RAPR 14-652 RAPR 14-654 RAPR 14-655 RAPR 14-657
7	57,2 60,3 63,5 70 73 76,1	G 2 G 2 1/2	2 1/4 2 1/2 2 3/4 3	RAPR 13-757,2 RAPR 13-760,3 RAPR 13-763,5 RAPR 13-770 RAPR 13-773 RAPR 13-776,1	RAPR 14-757,2 RAPR 14-760,3 RAPR 14-763,5 RAPR 14-770 RAPR 14-773 RAPR 14-776,1
8	88,9 101,8	G 3 G 3 1/2	3 1/2 4	RAPR 13-888,9 RAPR 13-8101,8	RAPR 14-888,9 RAPR 14-8101,8

Werden andere Kombinationen benötigt, so bestellen Sie diese bitte in Einzelteilen (Bestellzeichen hierfür siehe Seiten 14 – 18). Die Auslieferung erfolgt unmontiert in Einzelteilen. ¹⁾Schellen der Größe 0 werden in Abweichung von den Abbildungen nur mit einer Schraube befestigt ²⁾Aluminium in Größen 0 bis 6 ³⁾Bei Montage von Vollgummi-Schellen sind Deckplatten, Sechskantschrauben und Sicherungsscheiben zu verwenden ⁴⁾Vollgummi in Größen 1 bis 5
 If different combinations are required, we would be obliged if they could be ordered as separate components (Please refer to individual components, pages 14 – 18). Delivery in unassembled individual components. ¹⁾Contrary to illustration size 0 clamps are secured by only one screw ²⁾Aluminium in sizes 0 to 6 ³⁾When assembling solid rubber tube clamps, cover plates, hexagon screws and locking washers must be used ⁴⁾Rubber in sizes 1 to 5

ROHRSCHELLEN SERIE A | KOMPLETT-PROGRAMM

TUBE CLAMPS SERIES A | COMPLETE RANGE

Bestellzeichen

für Schellenhälften:

Polypropylen **RAPR**
 innen glatt **RAPG**
 Polyamid 6 **RANR**
 innen glatt **RANG**
 Vollgummi **RAVR^{3) 4)}**
RAVG³⁾

Aluminium **RAAR²⁾**

Bei Bedarf Standardkurzzeichen RAPR in der Spalte „Bestellzeichen“ austauschen.

Order codes

for clamp-halves:

Polypropylene **RAPR**
 inside smooth **RAPG**
 Polyamide 6 **RANR**
 inside smooth **RANG**
 Rubber **RAVR^{3) 4)}**
RAVG³⁾

Aluminium **RAAR²⁾**

Replace standard abbreviation RAPR in column "Order codes" as required.

2 Schellenhälften mit Deckplatte und Sechskantschrauben
 2 clamp halves, cover plate and hexagon head screws



2 Schellenhälften mit Aufbauschrauben und Sicherungsblechen
 2 clamp halves, stacking bolts and locking plates

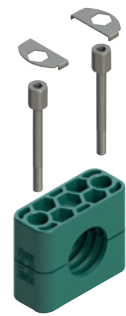

GRÖSSE SIZE	Rohr-AD mm O.D. mm	Rohr-NW Tube NB	Rohr-AD Zoll Inch O.D.	Bestellzeichen Order Codes	Bestellzeichen Order Codes
0 ¹⁾	4 6 6,4 8 9,5 10 12	G 1/8	5/16	RAPR 16-004 RAPR 16-006 RAPR 16-006,4 RAPR 16-008 RAPR 16-009,5 RAPR 16-010 RAPR 16-012	RAPR 18-004 RAPR 18-006 RAPR 18-006,4 RAPR 18-008 RAPR 18-009,5 RAPR 18-010 RAPR 18-012
1	4 6 6,4 8 9,5 10 12	G 1/8	5/16	RAPR 16-104 RAPR 16-106 RAPR 16-106,4 RAPR 16-108 RAPR 16-109,5 RAPR 16-110 RAPR 16-112	RAPR 18-104 RAPR 18-106 RAPR 18-106,4 RAPR 18-108 RAPR 18-109,5 RAPR 18-110 RAPR 18-112
2	12,7 13,5 14 15 16 17,2 18	G 1/4 G 3/8	1/2 5/8	RAPR 16-212,7 RAPR 16-213,5 RAPR 16-214 RAPR 16-215 RAPR 16-216 RAPR 16-217,2 RAPR 16-218	RAPR 18-212,7 RAPR 18-213,5 RAPR 18-214 RAPR 18-215 RAPR 18-216 RAPR 18-217,2 RAPR 18-218
3	19 20 21,3 22 23 25 25,4	G 1/2	3/4 1	RAPR 16-319 RAPR 16-320 RAPR 16-321,3 RAPR 16-322 RAPR 16-323 RAPR 16-325 RAPR 16-325,4	RAPR 18-319 RAPR 18-320 RAPR 18-321,3 RAPR 18-322 RAPR 18-323 RAPR 18-325 RAPR 18-325,4
4	26,9 28 30	G 3/4		RAPR 16-426,9 RAPR 16-428 RAPR 16-430	RAPR 18-426,9 RAPR 18-428 RAPR 18-430
5	32 33,7 35 38 40 42	G 1 G 1 1/4	1 1/4 1 1/2	RAPR 16-532 RAPR 16-533,7 RAPR 16-535 RAPR 16-538 RAPR 16-540 RAPR 16-542	RAPR 18-532 RAPR 18-533,7 RAPR 18-535 RAPR 18-538 RAPR 18-540 RAPR 18-542
6	44,5 45 48 50 50,8 52 54 55 57	G 1 1/2	1 3/4 2	RAPR 16-644,5 RAPR 16-645 RAPR 16-648 RAPR 16-650 RAPR 16-650,8 RAPR 16-652 RAPR 16-654 RAPR 16-655 RAPR 16-657	RAPR 18-644,5 RAPR 18-645 RAPR 18-648 RAPR 18-650 RAPR 18-650,8 RAPR 18-652 RAPR 18-654 RAPR 18-655 RAPR 18-657
7	57,2 60,3 63,5 70 73 76,1	G 2 G 2 1/2	2 1/4 2 1/2 2 3/4 3	RAPR 16-757,2 RAPR 16-760,3 RAPR 16-763,5 RAPR 16-770 RAPR 16-773 RAPR 16-776,1	RAPR 18-757,2 RAPR 18-760,3 RAPR 18-763,5 RAPR 18-770 RAPR 18-773 RAPR 18-776,1
8	88,9 101,8	G 3 G 3 1/2	3 1/2 4	RAPR 16-888,9 RAPR 16-8101,8	RAPR 18-888,9 RAPR 18-8101,8

Werden andere Kombinationen benötigt, so bestellen Sie diese bitte in Einzelteilen (Bestellzeichen hierfür siehe Seiten 14 – 18). Die Auslieferung erfolgt unmontiert in Einzelteilen. ¹⁾Schellen der Größe 0 werden in Abweichung von den Abbildungen nur mit einer Schraube befestigt ²⁾Aluminium in Größen 0 bis 6

³⁾Bei Montage von Vollgummi-Schellen sind Deckplatten, Sechskantschrauben und Sicherungsscheiben zu verwenden ⁴⁾Vollgummi in Größen 1 bis 5

If different combinations are required, we would be obliged if they could be ordered as separate components (Please refer to individual components, pages 14 – 18). Delivery in unassembled individual components. ¹⁾Contrary to illustration size 0 clamps are secured by only one screw ²⁾Aluminium in sizes 0 to 6

³⁾When assembling solid rubber tube clamps, cover plates, hexagon screws and locking washers must be used ⁴⁾Rubber in sizes 1 to 5

2+5 ... **DAS SYSTEM!**

NUR 2 ROHRSCHELLENGRÖSSEN

2+5 ... **THE SYSTEM!**

ONLY 2 TUBE CLAMP SIZES

Mit unserem 2+5 RSB-Rohrschellen-System werden mit nur 2 Baugrößen die Rohrdurchmesser 6 - 42 mm abgedeckt.

- leichte Montage, kombinierbar mit allen Ausführungen
- alle Metallteile können aus unserem Standardprogramm der DIN 3015 verwendet werden

With our 2+5 RSB-Tube clamps system you can fix all tube diameters between 6 and 42 mm with only 2 tube clamp sizes.

- easy assembly, can be combined with all versions
- all metal parts of our standard program according to DIN 3015 can be used



Nur eine Reihen-Anschweißplatte mit gleichmäßigen Bolzenabständen für alle Rohrschellen der Größe 2+5

Only one multiple weldplate with similar weldnut distances suits all tube clamps of size 2+5

ROHRSCHELLEN SERIE 2+5 (LEICHTBAUREIHE) | DIN 3015, TEIL 1 | EINZELTEILE
TUBE CLAMPS SERIES 2+5 (LIGHT CONSTRUCTION SERIES) | DIN 3015, PART 1 | COMPONENTS

Bestellzeichen für Schellenhälften:

Polypropylen **RAPR**
 innen glatt **RAPG²⁾**
 Polyamid 6 **RANR**
 innen glatt **RANG²⁾**
 Vollgummi **RAVR³⁾**
RAVG^{2) 3)}
 Aluminium **RAAR**

Bei Bedarf Standardkurzzeichen RAPR in der Spalte „Bestellzeichen“ austauschen.

Order codes for clamp-halves:

Polypropylene **RAPR**
 inside smooth **RAPG²⁾**
 Polyamide 6 **RANR**
 inside smooth **RANG²⁾**
 Rubber **RAVR³⁾**
RAVG^{2) 3)}
 Aluminium **RAAR**

Replace standard abbreviation RAPR in column "Order codes" as required.

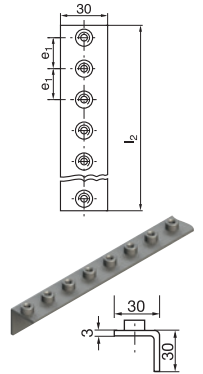
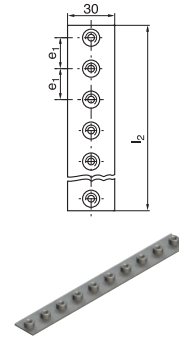
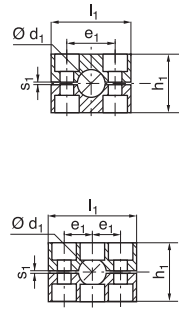
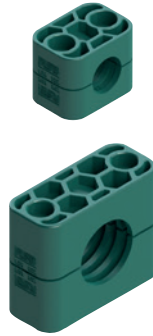

GRÖSSE SIZE	Rohr-AD mm O.D. mm	Rohr-NW Tube NB	Rohr-AD Zoll Inch O.D.	RAPR 1 St. / 2 Schellenhälften 1 part / 2 clamp-halves	RAPR-... 2 Schellenhälften 2 clamp-halves				APRL-A 2 Reihen-Anschweißplatte Multiple welding plate		APRWL-A 2 Winkel-Anschweißplatte Multiple welding plate, angled	
	d ₁				l ₁	h ₁	e ₁	s ₁	e ₁	l ₂	e ₁	l ₂
2	6			RAPR-206								
	6,4		1/4	RAPR-206,4								
	8		5/16	RAPR-208								
	9,5		3/8	RAPR-209,5								
	10	G 1/8		RAPR-210								
	12			RAPR-212								
	12,7		1/2	RAPR-212,7	42	33	26	0,8				
	13,5	G 1/4		RAPR-213,5								
	14			RAPR-214								
	15			RAPR-215								
5	16		5/8	RAPR-216								
	17,2	G 3/8		RAPR-217,2								
	18			RAPR-218								
	19		3/4	RAPR-519					26	508	26	508
	20			RAPR-520					20 Bolzen/Nuts		20 Bolzen/Nuts	
	21,3	G 1/2		RAPR-521,3								
	22			RAPR-522								
	23			RAPR-523								
	25			RAPR-525								
	25,4		1	RAPR-525,4								
	26,9	G 3/4		RAPR-526,9								
	28			RAPR-528	71	58	52	1,2				
	30			RAPR-530								
	32		1 1/4	RAPR-532								
33,7	G 1		RAPR-533,7									
35			RAPR-535									
38		1 1/2	RAPR-538									
40			RAPR-540									
42	G 1 1/4		RAPR-542									

Metallteile auch in Edelstahl lieferbar. Einzelteile hierfür siehe Seiten 14-18.

²⁾ohne Vorspannung

³⁾Bei Montage von Vollgummi-Schellen sind Deckplatten, Sechskantschrauben und Sicherungsscheiben zu verwenden

All metal parts available in stainless steel. Please refer to individual components pages 14-18.

²⁾without prestress

³⁾When assembling solid rubber tube clamps, cover plates, hexagon screws and locking washers must be used



SONDERSCHELLEN

INDIVIDUELLE LÖSUNGEN NACH MASS
STAHL, ALUMINIUM, POLYAMID, POLYPROPYLEN,
VOLLGUMMI, EDELSTAHL ...

SPECIAL CLAMPS

CUSTOM-BUILT TO ORDER
STEEL, ALUMINIUM, POLYAMIDE, POLYPROPYLENE,
THERMOPLASTIC RUBBER, STAINLESS STEEL ...

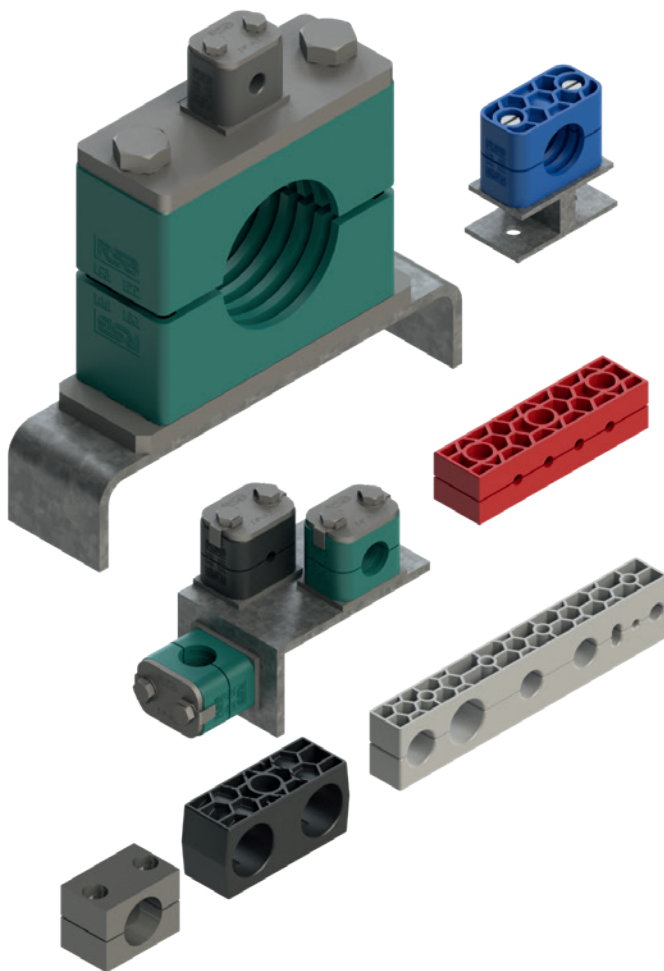

RSB[®]

RSB-SONDERSCHELLEN

lösen Ihr Befestigungsproblem dort,
wo Serienteile überfordert sind.

Modernste Technologie ermöglicht uns eine
flexible Umsetzung für Ihren Anwendungsfall.

Wir fertigen nach Kundenzeichnung oder
in Kooperation mit Ihnen, wir beraten Sie
fachmännisch, oder stehen Ihnen mit
hauseigenen Entwicklungen zur Seite.

SPRECHEN SIE MIT UNS!

RSB-SPECIAL CLAMPS

For solving your fixing problem that series
components cannot.

State-of-the-art technology ensures that we can
adapt to meet your individual requirements.

We work from a customer sketch or in cooperation
with you. We offer expert advice or support you
with our in-house developments.

WE ARE THE PEOPLE TO TALK TO!



// 03

ROHRSCHELLEN SERIE B

TUBE CLAMPS SERIES B

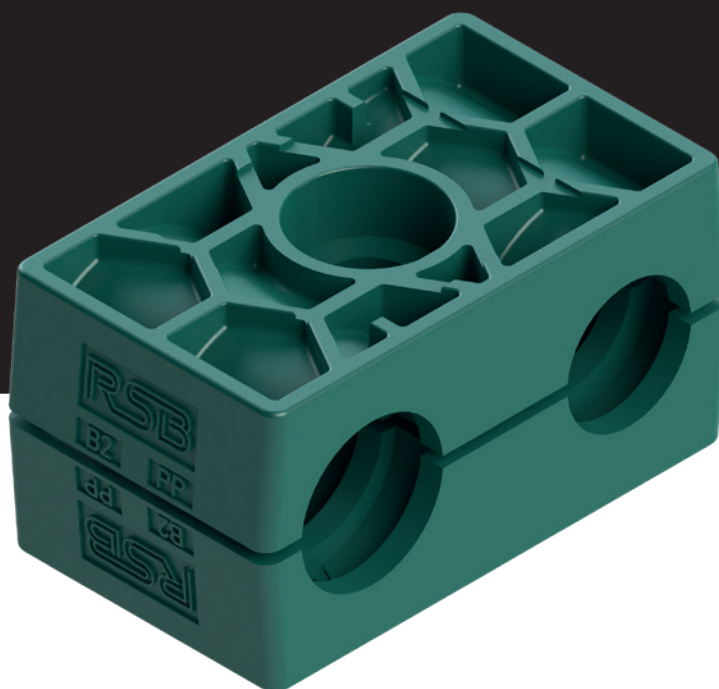

// ABMESSUNGEN UND GEWICHTE VON KOMPLETTSCHELLEN (MM)

// DIMENSIONS AND WEIGHTS OF TUBE CLAMPS, COMPLETE (MM)

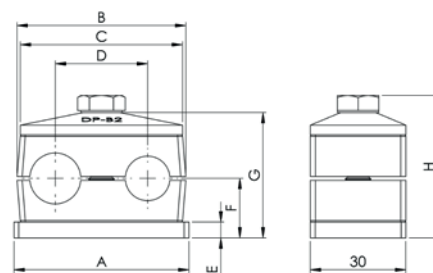

GRÖSSE SIZE	A	B	C	D	E	F		G		H		GEWICHT / 10 STK. WEIGHT / 10 PCS. RBPR3-xxx (kg)
						Rippen Grooved	Glatt Smooth	Rippen Grooved	Glatt Smooth	Rippen Grooved	Glatt Smooth	
1	37	36	34	20	3	16,5	16	37	36	41	40	0,74
2	55	53	51	29	5	18,7	18,1	39,4	38,2	44,7	43,5	1,32
3	70	67	64	36	5	23,5	22,7	49	47,4	54,3	52,7	1,73
4	85	82	78	45	5	26	25	54	52	59,3	57,3	2,13
5	110	106	102	56	5	32	31	66	64	71,3	69,3	3,01

Das Gewicht wurde mit dem kleinsten Durchmesser (siehe Katalog) und der Standard-Ausführung der Stahlteile der jeweiligen Größe in losen Zustand ermittelt.
The weight was determined with the smallest diameter (see catalogue) and the standard model of the steel parts of the respective quantity in bulk.

Bestellzeichen für Schellenhälften:

Polypropylen **RBPR**
 innen glatt **RBPG²⁾**
 Polyamid 6 **RBNR**
 innen glatt **RBNG²⁾**
 Vollgummi **RBVG^{2) 3)}**

Bei Bedarf Standardkurzzeichen RBPR in der Spalte „Schellenhälften“ austauschen.

Order codes for clamp-halves:

Polypropylene **RBPR**
 inside smooth **RBPG²⁾**
 Polyamide 6 **RBNR**
 inside smooth **RBNG²⁾**
 Rubber **RBVG^{2) 3)}**

Replace standard abbreviation RBPR in column "clamp-halves" as required.

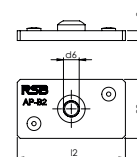
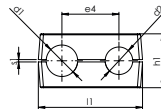

GRÖSSE SIZE	Rohr-AD mm O.D. mm	Rohr-NW Tube NB	Rohr-AD Zoll Inch O.D.	RBPR 1 St. / 2 Schellenhälften ¹⁾ 1 part / 2 clamp-halves ¹⁾	RBPR-... 2 Schellenhälften 2 clamp-halves	APZ3-B Anschweißplatte mit Verdrehsicherung Weld plate with locking device			
	d ₁ /d ₂				l ₁ h ₁ e ₄ s ₁	l ₂	s ₂	d ₆	
1	6	G 1/8	1/4	RBPR-106	36 27 20 1,0	APZ3-B 1 mit Verdrehsicherung with locking device	37	3	M 6
	6,4			RBPR-106,4					
	8			RBPR-108					
	9,5			RBPR-109,5					
	10			RBPR-110					
	12			RBPR-112					
2	12,7	G 3/8	5/8	RBPR-212,7	53 27,4 29 1,2	APZ3-B 2 mit Verdrehsicherung with locking device	55	5	M 8
	13,5			RBPR-213,5					
	14			RBPR-214					
	15			RBPR-215					
	16			RBPR-216					
	17,2			RBPR-217,2					
	18			RBPR-218					
3	19	G 1/2	3/4	RBPR-319	67 37 36 1,6	APZ3-B 3 mit Verdrehsicherung with locking device	70	5	M 8
	20			RBPR-320					
	21,3			RBPR-321,3					
	22			RBPR-322					
	25			RBPR-325					
	25,4			RBPR-325,4					
4	26,9	G 3/4	1	RBPR-426,9	82 42 45 2	APZ3-B 4 mit Verdrehsicherung with locking device	85	5	M 8
	28			RBPR-428					
	30			RBPR-430					
5	32	G 1 1/4	1 1/4	RBPR-532	106 54 56 2	APZ3-B 5 mit Verdrehsicherung with locking device	110	5	M 8
	33,7			RBPR-533,7					
	35			RBPR-535					
	38			RBPR-538					
	40			RBPR-540					
	42			RBPR-542					

Metallteile in Edelstahl lieferbar.

¹⁾Zweirohrschellen mit unterschiedlichen Rohr-AD auf Anfrage ²⁾ohne Vorspannung

³⁾Bei Montage von Vollgummi-Schellen sind Deckplatten, Sechskantschrauben und Sicherungsscheiben zu verwenden
 All metal parts available in stainless steel.

¹⁾Twin-tube clamps with different outer tube diameter upon request ²⁾without prestress

³⁾When assembling solid rubber tube clamps, cover plates, hexagon screws and locking washers must be used



ROHRSCHELLEN SERIE B (ZWEIROHRSCHELLE) | DIN 3015, TEIL 3 | EINZELTEILE
TUBE CLAMPS SERIES B (TWIN-TUBE CLAMP) | DIN 3015, PART 3 | COMPONENTS

Komplett-Programm siehe Seiten 34 bis 35. Complete range please refer to pages 34 to 35.

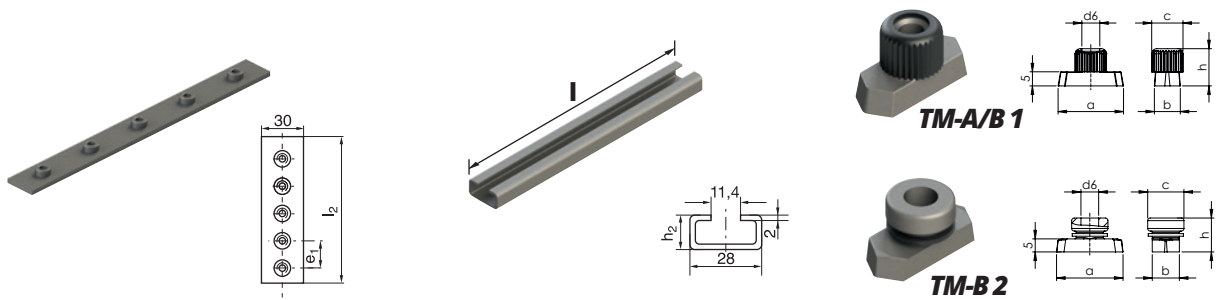

GRÖSSE SIZE	APR-B Reihen-Anschweißplatte Multiple weld plate		TS-A/B Tragschiene Mounting rail			TM Tragschienen-Mutter Rail nut						
	e ₁	l ₂		l	h ₂	a	b	c	d ₆	h		
1	APR-B 1 5 Schellen 5 Clamps	40	196				TM-A/B 1	25,4	10,4	12	M 6	14,5
2	APR-B 2 5 Schellen 5 Clamps	58	288	TS 11-A/B 1	1 m	11						
				TS 11-A/B 2	2 m	11						
3	APR-B 3 5 Schellen 5 Clamps	72	358	TS 14-A/B 1	1 m	14						
				TS 14-A/B 2	2 m	14						
				TS 30-A/B 1	1 m	30						
4	APR-B 4 5 Schellen 5 Clamps	90	446	TS 30-A/B 2	2 m	30	TM-B 2	25,4	10,4	14	M 8	13
5	APR-B 5 5 Schellen 5 Clamps	112	558									

Metallteile auch in Edelstahl lieferbar.
 All metal parts available in stainless steel.



ROHRSCHELLEN SERIE B (ZWEIROHRSCHELLE) | DIN 3015, TEIL 3 | EINZELTEILE
TUBE CLAMPS SERIES B (TWIN-TUBE CLAMP) | DIN 3015, PART 3 | COMPONENTS

Komplett-Programm siehe Seiten 34 bis 35. Complete range please refer to pages 34 to 35.



DIN 931/933

ISO 4762

GRÖSSE SIZE	DP-B Deckplatte Cover plate		SS-B Sechskantschraube Hexagon head screw			IS-B Innensechskantschraube Hexagon socket head screw					
	l ₃	d ₇	d	x	l	d	x	l			
1	DP-B 1	34	7	SS-B 1 (SSL-A 2)	M 6	x	35	IS-B 1 (IS-A 4)	M 6	x	35
2	DP-B 2	51	9	SS-B 2	M 8	x	35	IS-B 2	M 8	x	35
3	DP-B 3	64	9	SS-B 3	M 8	x	45	IS-B 3	M 8	x	45
4	DP-B 4	78	9	SS-B 4	M 8	x	50	IS-B 4	M 8	x	50
5	DP-B 5	102	9	SS-B 5	M 8	x	60	IS-B 5	M 8	x	60

Metallteile in Edelstahl lieferbar.
 All metal parts available in stainless steel.



Komplett-Programm siehe Seiten 34 bis 35. Complete range please refer to pages 34 to 35.

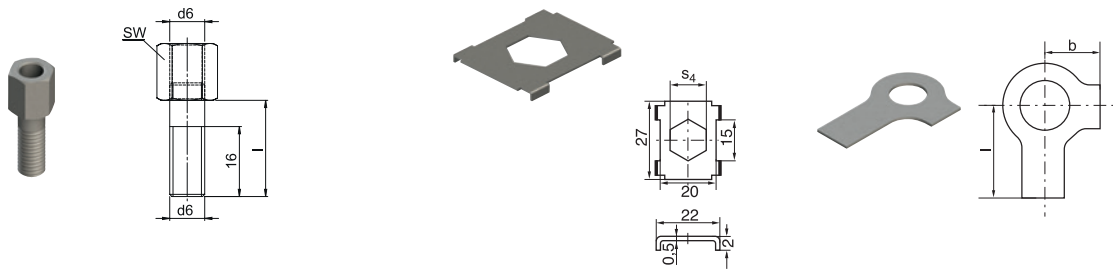

GRÖSSE SIZE	AS-B Aufbauschraube ¹⁾ Stacking bolt ¹⁾				SB-B Sicherungsblech ¹⁾ Locking plate ¹⁾		US Sicherungsscheibe ²⁾ Locking washer ²⁾		
		l	d ₆	SW		S ₄		b	l
1	AS-B 1 (AS-A 0/A 1)	20	M6	11	SB-B 1	11	US-A	9	18
2	AS-B 2	22	M 8	12	SB-B 2	12	US-B 2	11	20
3	AS-B 3	30	M 8	12					
4	AS-B 4	35	M 8	12					
5	AS-B 5	47	M 8	12					

Metallteile auch in Edelstahl lieferbar.

¹⁾Für den Einsatz von Aufbauschrauben bei Aufbaumontage sind Sicherungsbleche notwendig

²⁾Bei Montage von Vollgummi-Schellen sind Deckplatten, Sechskantschrauben und Sicherungsscheiben zu verwenden

All metal parts available in stainless steel.

¹⁾The usage of stacking bolts necessitates the deployment of locking plates during the construction assembly

²⁾When assembling solid rubber clamps, cover plates, hexagon screws and locking washers must be used



Bestellzeichen für Schellenhälften:

Polypropylen **RBPR**
 innen glatt **RBPG**
 Polyamid 6 **RBNR**
 innen glatt **RBNG**
 Vollgummi **RBVG³⁾**

Bei Bedarf Standardkurzzeichen RBPR in der Spalte „Bestellzeichen“ austauschen.

Order codes for clamp-halves:

Polypropylene **RBPR**
 inside smooth **RBPG**
 Polyamide 6 **RBNR**
 inside smooth **RBNG**
 Rubber **RBVG³⁾**

Replace standard abbreviation RBPR in column "Order codes" as required.

2 Schellenhälften mit Anschweißplatte, Deckplatte und Sechskantschraube
 2 clamp halves with weld plate, cover plate and hexagon head screw



2 Schellenhälften mit Anschweißplatte, Deckplatte und Innensechskantschraube
 2 clamp halves with weld plate, cover plate and hexagon socket head screw



2 Schellenhälften mit Trag-schiene-Mutter, Deckplatte und Sechskantschraube
 2 clamp halves with rail nut, cover plate and hexagon head screw



GRÖSSE SIZE	Rohr-AD mm O.D. mm	Rohr-NW Tube NB	Rohr-AD Zoll Inch O.D.	Bestellzeichen Order Codes	Bestellzeichen Order Codes	Bestellzeichen Order Codes
1	6			RBPR 1-106	RBPR 3-106	RBPR 4-106
	6,4		1/4	RBPR 1-106,4	RBPR 3-106,4	RBPR 4-106,4
	8		5/16	RBPR 1-108	RBPR 3-108	RBPR 4-108
	9,5		3/8	RBPR 1-109,5	RBPR 3-109,5	RBPR 4-109,5
	10	G 1/8		RBPR 1-110	RBPR 3-110	RBPR 4-110
	12			RBPR 1-112	RBPR 3-112	RBPR 4-112
2	12,7		1/2	RBPR 1-212,7	RBPR 3-212,7	RBPR 4-212,7
	13,5	G 1/4		RBPR 1-213,5	RBPR 3-213,5	RBPR 4-213,5
	14			RBPR 1-214	RBPR 3-214	RBPR 4-214
	15			RBPR 1-215	RBPR 3-215	RBPR 4-215
	16		5/8	RBPR 1-216	RBPR 3-216	RBPR 4-216
	17,2	G 3/8		RBPR 1-217,2	RBPR 3-217,2	RBPR 4-217,2
18			RBPR 1-218	RBPR 3-218	RBPR 4-218	
3	19		3/4	RBPR 1-319	RBPR 3-319	RBPR 4-319
	20			RBPR 1-320	RBPR 3-320	RBPR 4-320
	21,3			RBPR 1-321,3	RBPR 3-321,3	RBPR 4-321,3
	22	G 1/2		RBPR 1-322	RBPR 3-322	RBPR 4-322
	25			RBPR 1-325	RBPR 3-325	RBPR 4-325
	25,4		1	RBPR 1-325,4	RBPR 3-325,4	RBPR 4-325,4
4	26,9	G 3/4		RBPR 1-426,9	RBPR 3-426,9	RBPR 4-426,9
	28			RBPR 1-428	RBPR 3-428	RBPR 4-428
	30			RBPR 1-430	RBPR 3-430	RBPR 4-430
5	32		1 1/4	RBPR 1-532	RBPR 3-532	RBPR 4-532
	33,7			RBPR 1-533,7	RBPR 3-533,7	RBPR 4-533,7
	35	G 1		RBPR 1-535	RBPR 3-535	RBPR 4-535
	38		1 1/2	RBPR 1-538	RBPR 3-538	RBPR 4-538
	40			RBPR 1-540	RBPR 3-540	RBPR 4-540
	42	G 1 1/4		RBPR 1-542	RBPR 3-542	RBPR 4-542

Werden andere Kombinationen benötigt, so bestellen Sie diese bitte in Einzelteilen (Bestellzeichen hierfür siehe Seiten 30 – 33). Die Auslieferung erfolgt unmontiert in Einzelteilen.

³⁾Bei Montage von Vollgummi-Schellen sind Deckplatten, Sechskantschrauben und Sicherungsscheiben zu verwenden

If different combinations are required, we would be obliged if they could be ordered as separate components (Please refer to individual components, pages 30 – 33). Delivery in unassembled individual components.

³⁾When assembling solid rubber tube clamps, cover plates, hexagon screws and locking washers must be used

ROHRSCHELLEN SERIE B | KOMPLETT-PROGRAMM TUBE CLAMPS SERIES B | COMPLETE RANGE

Bestellzeichen für Schellenhälften:

Polypropylen **RBPR**
innen glatt **RBPG**
Polyamid 6 **RBNR**
innen glatt **RBNG**
Vollgummi **RBVG³⁾**

Bei Bedarf Standardkurzzeichen RBPR in der Spalte „Bestellzeichen“ austauschen.

Order codes for clamp-halves:

Polypropylene **RBPR**
inside smooth **RBPG**
Polyamide 6 **RBNR**
inside smooth **RBNG**
Rubber **RBVG³⁾**

Replace standard abbreviation RBPR in column "Order codes" as required.

2 Schellenhälften mit Tragschienen-Mutter, Deckplatte und Innensechskantschraube
2 clamp halves with rail nut, cover plate and hexagon socket head screw



2 Schellenhälften mit Aufbauschraube und Sicherungsblech
2 clamp halves with stacking bolt and locking plate



2 Schellenhälften mit Deckplatte und Sechskantschraube
2 clamp halves with cover plate and hexagon head screw



GRÖSSE SIZE	Rohr-AD mm O.D. mm d ₁	Rohr-NW Tube NB	Rohr-AD Zoll Inch O.D.	Bestellzeichen Order Codes	Bestellzeichen Order Codes	Bestellzeichen Order Codes
1	6	G 1/8	1/4	RBPR 5-106	RBPR 8-106	RBPR 16-106
	6,4			RBPR 5-106,4	RBPR 8-106,4	RBPR 16-106,4
	8			RBPR 5-108	RBPR 8-108	RBPR 16-108
	9,5			RBPR 5-109,5	RBPR 8-109,5	RBPR 16-109,5
	10			RBPR 5-110	RBPR 8-110	RBPR 16-110
	12			RBPR 5-112	RBPR 8-112	RBPR 16-112
2	12,7	G 3/8	1/2	RBPR 5-212,7	RBPR 8-212,7	RBPR 16-212,7
	13,5			RBPR 5-213,5	RBPR 8-213,5	RBPR 16-213,5
	14			RBPR 5-214	RBPR 8-214	RBPR 16-214
	15			RBPR 5-215	RBPR 8-215	RBPR 16-215
	16			RBPR 5-216	RBPR 8-216	RBPR 16-216
	17,2			RBPR 5-217,2	RBPR 8-217,2	RBPR 16-217,2
	18			RBPR 5-218	RBPR 8-218	RBPR 16-218
3	19	G 1/2	3/4	RBPR 5-319	RBPR 8-319	RBPR 16-319
	20			RBPR 5-320	RBPR 8-320	RBPR 16-320
	21,3			RBPR 5-321,3	RBPR 8-321,3	RBPR 16-321,3
	22			RBPR 5-322	RBPR 8-322	RBPR 16-322
	25			RBPR 5-325	RBPR 8-325	RBPR 16-325
	25,4			RBPR 5-325,4	RBPR 8-325,4	RBPR 16-325,4
4	26,9	G 3/4	1	RBPR 5-426,9	RBPR 8-426,9	RBPR 16-426,9
	28			RBPR 5-428	RBPR 8-428	RBPR 16-428
	30			RBPR 5-430	RBPR 8-430	RBPR 16-430
5	32	G 1	1 1/4	RBPR 5-532	RBPR 8-532	RBPR 16-532
	33,7			RBPR 5-533,7	RBPR 8-533,7	RBPR 16-533,7
	35			RBPR 5-535	RBPR 8-535	RBPR 16-535
	38			RBPR 5-538	RBPR 8-538	RBPR 16-538
	40			RBPR 5-540	RBPR 8-540	RBPR 16-540
	42			RBPR 5-542	RBPR 8-542	RBPR 16-542

Werden andere Kombinationen benötigt, so bestellen Sie diese bitte in Einzelteilen (Bestellzeichen hierfür siehe Seiten 30 – 33). Die Auslieferung erfolgt unmontiert in Einzelteilen.

³⁾Bei Montage von Vollgummi-Schellen sind Deckplatten, Sechskantschrauben und Sicherungsscheiben zu verwenden

If different combinations are required, we would be obliged if they could be ordered as separate components (Please refer to individual components, pages 30 – 33). Delivery in unassembled individual components.

³⁾When assembling solid rubber tube clamps, cover plates, hexagon screws and locking washers must be used

DAS INNOVATIVE DESIGN

- VON DER NATUR ABGESCHAUT - DIE WABENSTRUKTUR

INNOVATIVE DESIGN

- INSPIRED BY NATURE - HONEYCOMB-STRUCTURE

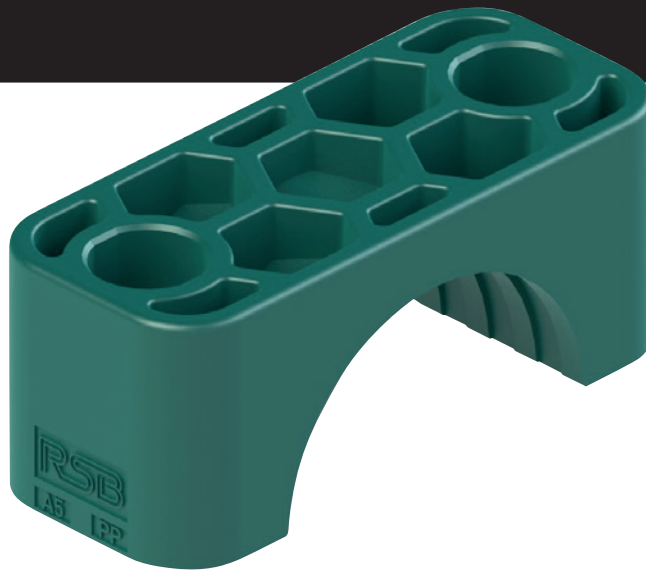

DIE VORTEILE

- Optimierte Produktgeometrie
- Beste Druckverteilung
- Höchstmögliche Rohrhaltekräfte

In allen Standardmaterialien verfügbar.

ADVANTAGES

- Optimized product-geometry
- Best possible distribution of pressure
- Highest possible tube holding force

All standard materials available.

// 04

ROHRSCHELLEN SERIE C

TUBE CLAMPS SERIES C

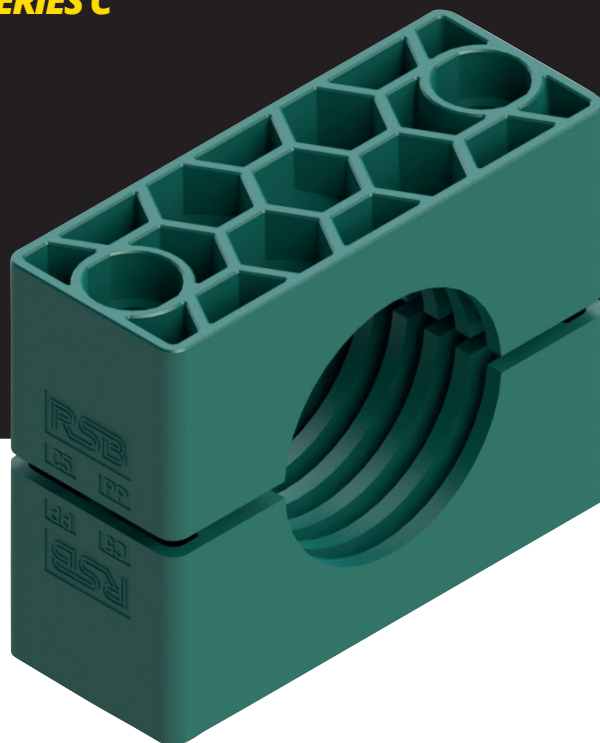

// ABMESSUNGEN UND GEWICHTE VON KOMPLETTSCHELLEN (MM)

// DIMENSIONS AND WEIGHTS OF TUBE CLAMPS, COMPLETE (MM)

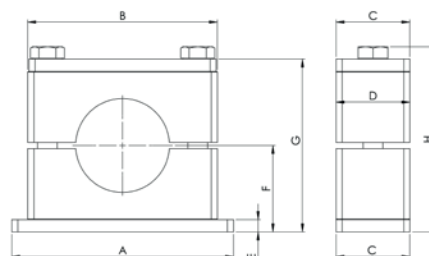

GRÖSSE SIZE	A	B	C	D	E	F		G		H		GEWICHT / 10 STK. WEIGHT / 10 PCS. RCPR3-xxx (kg)
						Rippen Grooved	Glatt Smooth	Rippen Grooved	Glatt Smooth	Rippen Grooved	Glatt Smooth	
1	73	56	30	30	8	24	23	48	46	54,4	52,4	0,31
2	84	71	30	30	8	32	31	64	62	70,4	68,4	0,41
3	100	86	30	30	8	38	37	76	74	82,4	80,4	0,48
4	140	117	45	45	10	55	53,5	110	107	117,5	114,5	1,24
5	180	154	60	60	10	70	67,5	140	135	150	145	2,43
6	225	206	80	80	15	99	96	198	192	210,5	204,5	6,12
7	270	251	90	90	15	115	112	230	224	245	239	8,69
8	340	320	120	120	25	160	157	320	314	333,7	327,7	22,49
9	520	470	160	162	30	235	-	470	-	488,7	-	51,23
10	680	630	180	182	30	295	-	590	-	608,7	-	74,38

Das Gewicht wurde mit dem kleinsten Durchmesser (siehe Katalog) und der Standard-Ausführung der Stahlteile der jeweiligen Größe in losen Zustand ermittelt.
The weight was determined with the smallest diameter (see catalogue) and the standard model of the steel parts of the respective quantity in bulk.

Bestellzeichen für Schellenhälften:

Polypropylen
 innen glatt **RCPR**
 innen glatt **RCPG^{1) 2)}**
 Polyamid 6 **RCNR**
 innen glatt **RCNG^{1) 2)}**
 Vollgummi **RCVR^{1) 3)}**
RCVG^{1) 2) 3)}

Aluminium **RCAR**

Bei Bedarf Standardkurzzeichen RCPR in der Spalte „Schellenhälften“ austauschen.

Order codes for clamp-halves:

Polypropylene inside smooth **RCPR**
 Polypropylene inside smooth **RCPG^{1) 2)}**
 Polyamide 6 inside smooth **RCNR**
 Polyamide 6 inside smooth **RCNG^{1) 2)}**
 Rubber **RCVR^{1) 3)}**
RCVG^{1) 2) 3)}

Aluminium **RCAR**

Replace standard abbreviation RCPR in column "clamp-halves" as required.

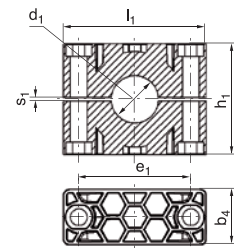
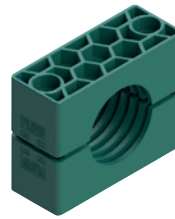

GRÖSSE SIZE	Rohr-AD mm O.D. mm	Rohr-NW Tube NB	Rohr-AD Zoll Inch O.D.	RCPR 1 Stück / 2 Schellenhälften 1 part / 2 clamp-halves	RCPR-... 2 Schellenhälften 2 clamp-halves				
	d ₁				l ₁	h ₁	e ₁	s ₁	b ₄
1	6	G 1/8	5/16	RCPR-106 RCPR-108 RCPR-109,5 RCPR-110 RCPR-112 RCPR-112,7 RCPR-113,5 RCPR-114 RCPR-115 RCPR-116 RCPR-117,2 RCPR-118	56	32	33	2	30
	8								
	9,5		3/8						
	10								
	12	G 1/4	1/2						
	12,7								
	13,5								
	14								
	15	G 3/8	5/8						
	16								
17,2									
18									
2	19	G 1/2	3/4	RCPR-219 RCPR-220 RCPR-221,3 RCPR-222 RCPR-223 RCPR-225 RCPR-225,4 RCPR-226,9 RCPR-228 RCPR-230	71	48	45	2	30
	20								
	21,3								
	22								
	23	G 3/4	1						
	25								
	25,4								
	26,9								
	28								
	30								
3	30	G 1	1 1/4	RCPR-330 RCPR-332 RCPR-333,7 RCPR-335 RCPR-338 RCPR-340 RCPR-342	86	60	60	2	30
	32								
	33,7								
	35								
	38	G 1 1/4	1 1/2						
	40								
42									
4	38	G 1 1/4	1 1/2	RCPR-438 RCPR-440 RCPR-442 RCPR-445 RCPR-448,3 RCPR-450 RCPR-451 RCPR-452 RCPR-455 RCPR-457 RCPR-460,3 RCPR-463 RCPR-465 RCPR-470	117	90	90	3	45
	40								
	42								
	45								
	48,3	G 1 1/2	2						
	50								
	51								
	52								
	55	G 2	2 1/4						
	57								
	60,3								
	63		2 1/2						
65									
70	2 3/4								

¹⁾Nur in Größen 1 – 8 ²⁾ohne Vorspannung

³⁾Bei Montage von Vollgummi-Schellen sind Deckplatten, Sechskantschrauben und Sicherungsscheiben zu verwenden

¹⁾Only sizes 1 – 8 ²⁾without prestress

³⁾When assembling solid rubber tube clamps, cover plates, hexagon screws and locking washers must be used

ROHRSCHELLEN SERIE C (SCHWERE BAUREIHE) | DIN 3015, TEIL 2 | EINZELTEILE
TUBE CLAMPS SERIES C (HEAVY SERIES) | DIN 3015, PART 2 | COMPONENTS

Bestellzeichen für Schellenhälften:

Polypropylen
 innen glatt **RCPR**
 Polyamid 6
 innen glatt **RCPG^{1) 2)}**
 Vollgummi **RCNR**
RCNG^{1) 2)}
RCVR^{1) 3)}
RCVG^{1) 2) 3)}

Aluminium **RCAR**

Bei Bedarf Standardkurzzeichen RCPR in der Spalte „Schellenhälften“ austauschen.

Order codes for clamp-halves:

Polypropylene
 inside smooth **RCPR**
 Polyamide 6
 inside smooth **RCPG^{1) 2)}**
 Rubber **RCNR**
RCNG^{1) 2)}
RCVR^{1) 3)}
RCVG^{1) 2) 3)}

Aluminium **RCAR**

Replace standard abbreviation RCPR in column "clamp-halves" as required.

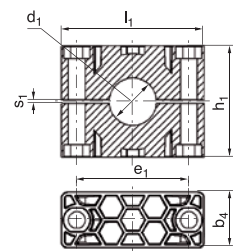
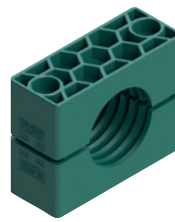

GRÖSSE SIZE	Rohr-AD mm O.D. mm	Rohr-NW Tube NB	Rohr-AD Zoll Inch O.D.	RCPR 1 Stück / 2 Schellenhälften 1 part / 2 clamp-halves	RCPR... 2 Schellenhälften 2 clamp-halves				
	d ₁				l ₁	h ₁	e ₁	s ₁	b ₄
5	65	G 2 1/2	3	RCPR-565	154	120	122	5	60
	70			RCPR-570					
	73			RCPR-573					
	75			RCPR-575					
	76,1			RCPR-576,1					
	80	RCPR-580							
	82,5	RCPR-582,5							
	85	RCPR-585							
	88,9	RCPR-588,9							
90	G 3	3 1/2	RCPR-590						
6	90	G 3 1/2	4	RCPR-690	206	168	168	6	80
	97			RCPR-697					
	100			RCPR-6100					
	101,6	RCPR-6101,6							
	108	RCPR-6108							
	114,3	G 4	4 1/2	RCPR-6114,3					
	127	5	RCPR-6127						
7	127	G 5	5	RCPR-7127	251	200	205	6	90
	130			RCPR-7130					
	133			RCPR-7133					
	140	RCPR-7140							
	150	RCPR-7150							
	152,4	G 6	6	RCPR-7152,4					
	159			RCPR-7159					
	165,1			RCPR-7165,1					
	168,3	RCPR-7168,3							
8	168,3	G 6	8	RCPR-8168,3	320	270	265	6	120
	177,8			RCPR-8177,8					
	193,7			RCPR-8193,7					
	203	RCPR-8203							
	219,1	G 8	RCPR-8219,1						
	220		RCPR-8220						
9	219,1	G 8		RCPR-9219,1	470	410	395	20	162
	244,5			RCPR-9244,5					
	273	G 10		RCPR-9273					
	323,9	G 12		RCPR-9323,9					
10	355,6	G 14		RCPR-10355,6	630	530	534	20	182
	406,4			G 16					

¹⁾Nur in Größen 1 – 8 ²⁾ohne Vorspannung ³⁾Bei Montage von Vollgummi-Schellen sind Deckplatten, Sechskantschrauben und Sicherungsscheiben zu verwenden
¹⁾Only sizes 1 – 8 ²⁾without prestress ³⁾When assembling solid rubber tube clamps, cover plates, hexagon screws and locking washers must be used

ROHRSCHELLEN SERIE C (SCHWERE BAUREIHE) | DIN 3015, TEIL 2 | EINZELTEILE
TUBE CLAMPS SERIES C (HEAVY SERIES) | DIN 3015, PART 2 | COMPONENTS

Komplett-Programm siehe Seiten 43 bis 48. Complete range please refer to pages 43 to 48.

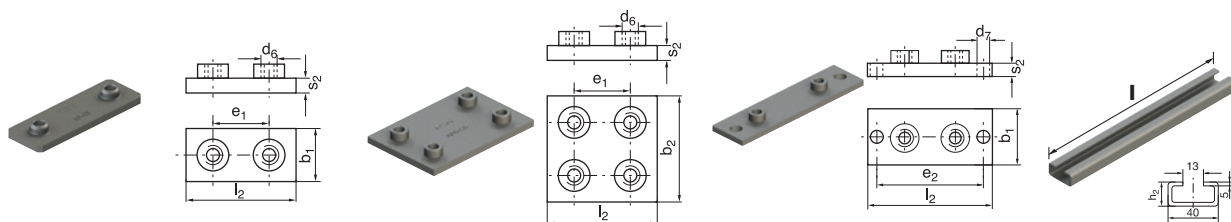

GRÖSSE SIZE	AP-C Anschweißplatte Weld plate						APD-C Anschweißplatte, doppelt Weld plate, double						APL-C Anschweiß- u. Schraubplatte Weld- and screw plate, elongated						TS-C Tragschiene Mounting rail		
	e ₁	b ₁	l ₂	s ₂	d ₆		e ₁	b ₂	l ₂	s ₂	d ₆		l ₂	b ₁	s ₂	e ₂	d ₇		l	h ₂	
1	AP-C 1	33	30	73	8	M 10	APD-C 1	33	60	73	8	M 10	APL-C 1	113	30	8	85	11	TS-C 1 TS-C 2	1m 2m	22
2	AP-C 2	45	30	84	8	M 10	APD-C 2	45	60	84	8	M 10	APL-C 2	125	30	8	97	11			
3	AP-C 3	60	30	100	8	M 10	APD-C 3	60	60	100	8	M 10	APL-C 3	140	30	8	112	11			
4	AP-C 4	90	45	140	10	M 12	APD-C 4	90	90	140	10	M 12	APL-C 4	190	45	10	160	14			
5	AP-C 5	122	60	180	10	M 16	APD-C 5	122	120	180	10	M 16	APL-C 5	240	60	10	205	18			
6	AP-C 6	168	80	225	15	M 20	APD-C 6	168	160	225	15	M 20	APL-C 6	310	80	15	270	22			
7	AP-C 7	205	90	270	15	M 24	APD-C 7	205	180	270	15	M 24	APL-C 7	370	90	15	320	26			
8	AP-C 8	265	120	340	25	M 30	APD-C 8	265	240	340	25	M 30	APL-C 8	450	120	25	390	33			
9	AP-C 9	395	160	520	30	M 30	APD-C 9	395	330	520	30	M 30									
10	AP-C 10	534	180	680	30	M 30	APD-C 10	534	370	680	30	M 30									

Metallteile in Edelstahl lieferbar.
 All metal parts available in stainless steel.



ROHRSCHELLEN SERIE C (SCHWERE BAUREIHE) | DIN 3015, TEIL 2 | EINZELTEILE
TUBE CLAMPS SERIES C (HEAVY SERIES) | DIN 3015, PART 2 | COMPONENTS

Komplett-Programm siehe Seiten 43 bis 48. Complete range please refer to pages 43 to 48.

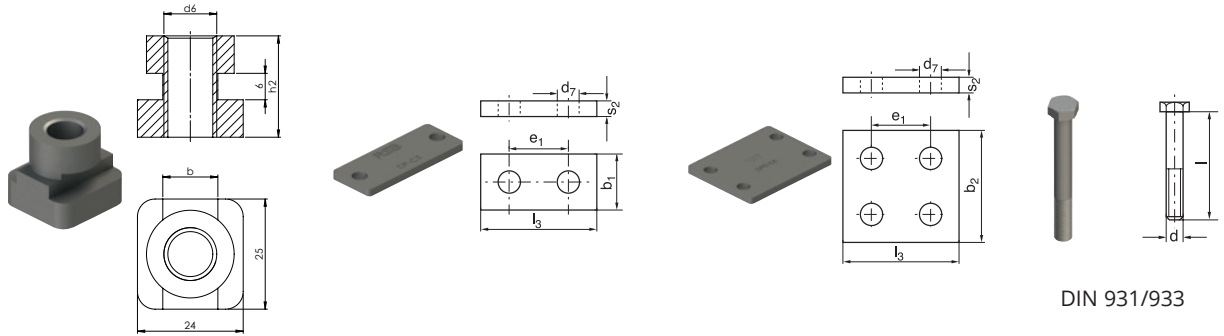

DIN 931/933

GRÖSSE SIZE	TM-C Tragschienen-Mutter Rail nut			DP-C Deckplatte Cover plate					DPD-C Deckplatte, doppelt Cover plate, double					SS-C Sechskantschraube Hexagon head screw				
	h ₂	b	d ₆	l ₃	e ₁	b ₁	s ₂	d ₇	l ₃	e ₁	b ₂	s ₂	d ₇	d	x	l		
1				DP-C 1	55	33	30	8	11	DPD-C 1	55	33	60	8	11	SS-C 1	M 10 x 40	
2	TM-C 1	20	12	M 10	DP-C 2	70	45	30	8	11	DPD-C 2	70	45	60	8	11	SS-C 2	M 10 x 60
3					DP-C 3	85	60	30	8	11	DPD-C 3	85	60	60	8	11	SS-C 3	M 10 x 70
4	TM-C 4	23	12,5	M 12	DP-C 4	115	90	45	10	14	DPD-C 4	115	90	90	10	14	SS-C 4	M 12 x 100
5					DP-C 5	152	122	60	10	18	DPD-C 5	152	122	120	10	18	SS-C 5	M 16 x 130
6					DP-C 6	205	168	80	15	22	DPD-C 6	205	168	160	15	24	SS-C 6	M 20 x 190
7					DP-C 7	251	205	90	15	28	DPD-C 7	250	205	180	15	28	SS-C 7	M 24 x 220
8					DP-C 8	320	265	120	25	35	DPD-C 8	322	265	240	25	35	SS-C 8	M 30 x 300
9					DP-C 9	470	395	160	30	35	DPD-C 9	470	395	330	30	35	SS-C 9 ¹⁾	M 30 x 450
10					DP-C 10	630	534	180	30	35	DPD-C 10	630	534	360	30	35	SS-C 10 ¹⁾	M 30 x 560

Metallteile in Edelstahl lieferbar.

¹⁾ Länge nicht handelsüblich - evtl. längere Lieferzeit

All metal parts available in stainless steel.

¹⁾ length not commercially available - extended lead time may occur



Komplett-Programm siehe Seiten 43 bis 48. Complete range please refer to pages 43 to 48.

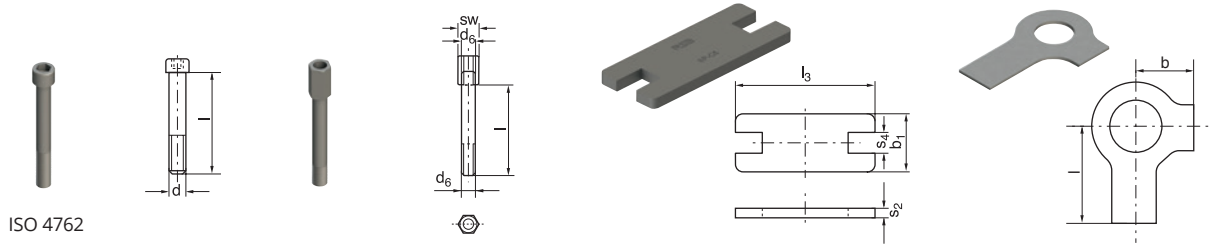

GRÖSSE SIZE	IS-C Innensechskantschraube Hexagon socket head screw			AS-C Aufbauschraube ¹⁾ Stacking bolt ¹⁾			SP-C Sicherungsplatte ¹⁾ Locking plate ¹⁾				US-C Sicherungsscheibe ²⁾ Locking washer ²⁾				
		d	x	l	l	d ₆	sw	l ₃	b ₁	s ₂	s ₄	b	l		
1	IS-C 1	M 10	x	40	AS-C 1	25	M 10	15	SP-C 1	55	30	8	15,5		
2	IS-C 2	M 10	x	60	AS-C 2	40	M 10	15	SP-C 2	70	30	8	15,5	US-C 1	13 22
3	IS-C 3	M 10	x	70	AS-C 3	50	M 10	15	SP-C 3	85	30	8	15,5		
4	IS-C 4	M 12	x	100	AS-C 4	80	M 12	17	SP-C 4	115	45	10	17,5	US-C 4	15 28
5	IS-C 5	M 16	x	130	AS-C 5	110	M 16	21	SP-C 5	152	60	10	21,5	US-C 5	18 32
6	IS-C 6	M 20	x	190	AS-C 6	155	M 20	27	SP-C 6	205	80	15	27,5	US-C 6	21 36
7	IS-C 7 ³⁾	M 24	x	220	AS-C 7	180	M 24	30	SP-C 7	250	90	15	30,5	US-C 7	25 42
8	IS-C 8 ³⁾	M 30	x	300	AS-C 8	250	M 30	36	SP-C 8	320	120	25	36,5	US-C 8	32 52
9	IS-C 9 ³⁾	M 30	x	450											
10	IS-C 10 ³⁾	M 30	x	560											

Metallteile in Edelstahl lieferbar.

¹⁾Für den Einsatz von Aufbauschrauben bei Aufbaumontage sind Sicherungsplatten notwendig

²⁾Bei Montage von Vollgummi-Schellen sind Deckplatten, Sechskantschrauben und Sicherungsscheiben zu verwenden

³⁾ Länge nicht handelsüblich – evtl. längere Lieferzeit

All metal parts available in stainless steel.

¹⁾The usage of stacking bolts necessitates the deployment of locking plates during the construction assembly

²⁾When assembling solid rubber clamps, cover plates, hexagon screws and locking washers must be used

³⁾ length not commercially available – extended lead time may occur



ROHRSCHELLEN SERIE C | KOMPLETT-PROGRAMM

TUBE CLAMPS SERIES C | COMPLETE RANGE

Bestellzeichen

für Schellenhälften:

Polypropylen
innen glatt
Polyamid 6
innen glatt
Vollgummi

Aluminium

RCPR
RCPG¹⁾
RCNR
RCNG¹⁾
RCVR^{1) 3)}
RCVG^{1) 3)}

RCAR

Bei Bedarf Standardkurzzeichen RCPR in der Spalte „Bestellzeichen“ austauschen.

Order codes

for clamp-halves:

Polypropylene
inside smooth
Polyamide 6
inside smooth
Rubber

Aluminium

RCPR
RCPG¹⁾
RCNR
RCNG¹⁾
RCVR^{1) 3)}
RCVG^{1) 3)}

RCAR

Replace standard abbreviation RCPR in column "Order codes" as required.

2 Schellenhälften mit
Anschweißplatte, Deckplatte
und Sechskantschrauben
2 clamp halves with weld plate,
cover plate and hexagon head screws



2 Schellenhälften mit
Anschweißplatte, Deckplatte
und Innensechskantschrauben
2 clamp halves with weld plate,
cover plate and hexagon socket head screws



GRÖSSE SIZE	Rohr-AD mm O.D. mm	Rohr-NW Tube NB	Rohr-AD Zoll Inch O.D.	Bestellzeichen Order Codes	Bestellzeichen Order Codes
1	6	G 1/8	5/16 3/8	RCPR 1-106	RCPR 2-106
	8			RCPR 1-108	RCPR 2-108
	9,5			RCPR 1-109,5	RCPR 2-109,5
	10			RCPR 1-110	RCPR 2-110
	12	G 1/4	1/2	RCPR 1-112	RCPR 2-112
	12,7			RCPR 1-112,7	RCPR 2-112,7
	13,5			RCPR 1-113,5	RCPR 2-113,5
	14			RCPR 1-114	RCPR 2-114
	15	G 3/8	5/8	RCPR 1-115	RCPR 2-115
	16			RCPR 1-116	RCPR 2-116
17,2	RCPR 1-117,2			RCPR 2-117,2	
18	RCPR 1-118			RCPR 2-118	
2	19	G 1/2	3/4	RCPR 1-219	RCPR 2-219
	20			RCPR 1-220	RCPR 2-220
	21,3			RCPR 1-221,3	RCPR 2-221,3
	22			RCPR 1-222	RCPR 2-222
	23	G 3/4	1	RCPR 1-223	RCPR 2-223
	25			RCPR 1-225	RCPR 2-225
	25,4			RCPR 1-225,4	RCPR 2-225,4
	26,9			RCPR 1-226,9	RCPR 2-226,9
	28			RCPR 1-228	RCPR 2-228
	30			RCPR 1-230	RCPR 2-230
3	30	G 1	1 1/4	RCPR 1-330	RCPR 2-330
	32			RCPR 1-332	RCPR 2-332
	33,7			RCPR 1-333,7	RCPR 2-333,7
	35			RCPR 1-335	RCPR 2-335
	38	G 1 1/4	1 1/2	RCPR 1-338	RCPR 2-338
	40			RCPR 1-340	RCPR 2-340
42	RCPR 1-342	RCPR 2-342			
4	38	G 1 1/4	1 1/2	RCPR 1-438	RCPR 2-438
	40			RCPR 1-440	RCPR 2-440
	42			RCPR 1-442	RCPR 2-442
	45	G 1 1/2	2	RCPR 1-445	RCPR 2-445
	48,3			RCPR 1-448,3	RCPR 2-448,3
	50			RCPR 1-450	RCPR 2-450
	51	G 2	2 1/4	RCPR 1-451	RCPR 2-451
	52			RCPR 1-452	RCPR 2-452
	55			RCPR 1-455	RCPR 2-455
	57	2 1/2	2 1/2	RCPR 1-457	RCPR 2-457
	60,3			RCPR 1-460,3	RCPR 2-460,3
	63			RCPR 1-463	RCPR 2-463
	65			RCPR 1-465	RCPR 2-465
70			RCPR 1-470	RCPR 2-470	

Werden andere Kombinationen benötigt, so bestellen Sie diese bitte in Einzelteilen (Bestellzeichen hierfür siehe Seiten 38 – 42).

Die Auslieferung erfolgt unmontiert in Einzelteilen. ¹⁾Nur in Größen 1 – 8 ²⁾Bei Montage von Vollgummi-Schellen sind Deckplatten, Sechskantschrauben und Sicherungsscheiben zu verwenden

If different combinations are required, we would be obliged if they could be ordered as separate components (Please refer to individual components, pages 38 – 42). Delivery in unassembled individual components. ¹⁾Only sizes 1 – 8 ²⁾When assembling solid rubber tube clamps, cover plates, hexagon screws and locking washers must be used

Bestellzeichen für Schellenhälften:

Polypropylen **RCPR**
 innen glatt **RCPG¹⁾**
 Polyamid 6 **RCNR**
 innen glatt **RCNG¹⁾**
 Vollgummi **RCVR^{1) 3)}**
RCVG^{1) 3)}
 Aluminium **RCAR**

Bei Bedarf Standardkurzzeichen RCPR in der Spalte „Bestellzeichen“ austauschen.

Order codes for clamp-halves:

Polypropylene **RCPR**
 inside smooth **RCPG¹⁾**
 Polyamide 6 **RCNR**
 inside smooth **RCNG¹⁾**
 Rubber **RCVR^{1) 3)}**
RCVG^{1) 3)}
 Aluminium **RCAR**

Replace standard abbreviation RCPR in column "Order codes" as required.

2 Schellenhälften mit Anschweißplatte, Deckplatte und Sechskantschrauben
 2 clamp halves with weld plate, cover plate and hexagon head screws



2 Schellenhälften mit Anschweißplatte, Deckplatte und Innensechskantschrauben
 2 clamp halves with weld plate, cover plate and hexagon socket head screws



GRÖSSE <i>SIZE</i>	<i>Rohr-AD mm</i> O.D. mm	<i>Rohr-NW</i> Tube NB	<i>Rohr-AD Zoll</i> Inch O.D.	<i>Bestellzeichen</i> Order Codes	<i>Bestellzeichen</i> Order Codes
5	65	G 2 1/2	2 3/4	RCPR 1-565	RCPR 2-565
	70			RCPR 1-570	RCPR 2-570
	73			RCPR 1-573	RCPR 2-573
	75			RCPR 1-575	RCPR 2-575
	76,1			RCPR 1-576,1	RCPR 2-576,1
	80	G 3	3	RCPR 1-580	RCPR 2-580
	82,5			RCPR 1-582,5	RCPR 2-582,5
	85			RCPR 1-585	RCPR 2-585
	88,9			RCPR 1-588,9	RCPR 2-588,9
	90			RCPR 1-590	RCPR 2-590
6	90	G 3 1/2	4	RCPR 1-690	RCPR 2-690
	97			RCPR 1-697	RCPR 2-697
	100			RCPR 1-6100	RCPR 2-6100
	101,6	G 4	4 1/2	RCPR 1-6101,6	RCPR 2-6101,6
	108			RCPR 1-6108	RCPR 2-6108
	114,3			RCPR 1-6114,3	RCPR 2-6114,3
127	G 6	5	RCPR 1-6127	RCPR 2-6127	
127			RCPR 1-7127	RCPR 2-7127	
7	130	G 5	5	RCPR 1-7130	RCPR 2-7130
	133			RCPR 1-7133	RCPR 2-7133
	140			RCPR 1-7140	RCPR 2-7140
	150			RCPR 1-7150	RCPR 2-7150
	152,4	G 6	6	RCPR 1-7152,4	RCPR 2-7152,4
	159			RCPR 1-7159	RCPR 2-7159
	165,1			RCPR 1-7165,1	RCPR 2-7165,1
	168,3			RCPR 1-7168,3	RCPR 2-7168,3
8	168,3	G 6	8	RCPR 1-8168,3	RCPR 2-8168,3
	177,8			RCPR 1-8177,8	RCPR 2-8177,8
	193,7			RCPR 1-8193,7	RCPR 2-8193,7
	203	G 8	8	RCPR 1-8203	RCPR 2-8203
	219,1			RCPR 1-8219,1	RCPR 2-8219,1
	220			RCPR 1-8220	RCPR 2-8220
9	219,1	G 8		RCPR 1-9219,1	RCPR 2-9219,1
	244,5	G 10		RCPR 1-9244,5	RCPR 2-9244,5
	273			RCPR 1-9273	RCPR 2-9273
	323,9	G 12		RCPR 1-9323,9	RCPR 2-9323,9
10	355,6	G 14		RCPR 1-10355,6	RCPR 2-10355,6
	406,4	G 16		RCPR 1-10406,4	RCPR 2-10406,4

Werden andere Kombinationen benötigt, so bestellen Sie diese bitte in Einzelteilen (Bestellzeichen hierfür siehe Seiten 38 – 42). Die Auslieferung erfolgt unmontiert in Einzelteilen. ¹⁾Nur in Größen 1 – 8 ³⁾Bei Montage von Vollgummi-Schellen sind Deckplatten, Sechskantschrauben und Sicherungsscheiben zu verwenden

If different combinations are required, we would be obliged if they could be ordered as separate components (Please refer to individual components, pages 38 – 42). Delivery in unassembled individual components. ¹⁾Only sizes 1 – 8 ³⁾When assembling solid rubber tube clamps, cover plates, hexagon screws and locking washers must be used

ROHRSCHELLEN SERIE C | KOMPLETT-PROGRAMM
TUBE CLAMPS SERIES C | COMPLETE RANGE

Bestellzeichen für Schellenhälften:

Polypropylen **RCPR**
 innen glatt **RCPG¹⁾**
 Polyamid 6 **RCNR**
 innen glatt **RCNG¹⁾**
 Vollgummi **RCVR^{1) 3)}**
RCVG^{1) 3)}
 Aluminium **RCAR**

Bei Bedarf Standardkurzzeichen RCPR in der Spalte „Bestellzeichen“ austauschen.

Order codes for clamp-halves:

Polypropylene **RCPR**
 inside smooth **RCPG¹⁾**
 Polyamide 6 **RCNR**
 inside smooth **RCNG¹⁾**
 Rubber **RCVR^{1) 3)}**
RCVG^{1) 3)}
 Aluminium **RCAR**

Replace standard abbreviation RCPR in column "Order codes" as required.

2 Schellenhälften mit Tragschienen-Muttern, Deckplatte und Sechskantschrauben
 2 clamp halves with rail nut, cover plate and hexagon head screws



2 Schellenhälften mit Tragschienen-Muttern, Deckplatte und Innensechskantschrauben
 2 clamp halves with rail nut, cover plate and hexagon socket head screws



2 Schellenhälften mit Aufbauschrauben und Sicherungsplatte
 2 clamp halves with stacking bolts and locking plate

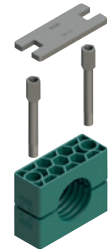

GRÖSSE SIZE	Rohr-AD mm O.D. mm	Rohr-NW Tube NB	Rohr-AD Zoll Inch O.D.	Bestellzeichen Order Codes	Bestellzeichen Order Codes	Bestellzeichen Order Codes
1	6	G 1/8	5/16	RCPR 3-106	RCPR 4-106	RCPR 5-106
	8			RCPR 3-108	RCPR 4-108	RCPR 5-108
	9,5			RCPR 3-109,5	RCPR 4-109,5	RCPR 5-109,5
	10			RCPR 3-110	RCPR 4-110	RCPR 5-110
	12			RCPR 3-112	RCPR 4-112	RCPR 5-112
	12,7	G 1/4	1/2	RCPR 3-112,7	RCPR 4-112,7	RCPR 5-112,7
	13,5			RCPR 3-113,5	RCPR 4-113,5	RCPR 5-113,5
	14			RCPR 3-114	RCPR 4-114	RCPR 5-114
	15	G 3/8	5/8	RCPR 3-115	RCPR 4-115	RCPR 5-115
	16			RCPR 3-116	RCPR 4-116	RCPR 5-116
	17,2			RCPR 3-117,2	RCPR 4-117,2	RCPR 5-117,2
	18			RCPR 3-118	RCPR 4-118	RCPR 5-118
	2			19	G 1/2	3/4
20		RCPR 3-220	RCPR 4-220	RCPR 5-220		
21,3		RCPR 3-221,3	RCPR 4-221,3	RCPR 5-221,3		
22		RCPR 3-222	RCPR 4-222	RCPR 5-222		
23		RCPR 3-223	RCPR 4-223	RCPR 5-223		
25		G 3/4	1	RCPR 3-225	RCPR 4-225	RCPR 5-225
25,4				RCPR 3-225,4	RCPR 4-225,4	RCPR 5-225,4
26,9				RCPR 3-226,9	RCPR 4-226,9	RCPR 5-226,9
28				RCPR 3-228	RCPR 4-228	RCPR 5-228
30				RCPR 3-230	RCPR 4-230	RCPR 5-230
3	30	G 1	1 1/4	RCPR 3-330	RCPR 4-330	RCPR 5-330
	32			RCPR 3-332	RCPR 4-332	RCPR 5-332
	33,7			RCPR 3-333,7	RCPR 4-333,7	RCPR 5-333,7
	35	G 1 1/4	1 1/2	RCPR 3-335	RCPR 4-335	RCPR 5-335
	38			RCPR 3-338	RCPR 4-338	RCPR 5-338
	40			RCPR 3-340	RCPR 4-340	RCPR 5-340
42	RCPR 3-342	RCPR 4-342	RCPR 5-342			
4	38	G 1 1/4	1 1/2	RCPR 3-438	RCPR 4-438	RCPR 5-438
	40			RCPR 3-440	RCPR 4-440	RCPR 5-440
	42			RCPR 3-442	RCPR 4-442	RCPR 5-442
	45	G 1 1/2	2	RCPR 3-445	RCPR 4-445	RCPR 5-445
	48,3			RCPR 3-448,3	RCPR 4-448,3	RCPR 5-448,3
	50			RCPR 3-450	RCPR 4-450	RCPR 5-450
	51			RCPR 3-451	RCPR 4-451	RCPR 5-451
	52			RCPR 3-452	RCPR 4-452	RCPR 5-452
	55	G 2	2 1/4	RCPR 3-455	RCPR 4-455	RCPR 5-455
	57			RCPR 3-457	RCPR 4-457	RCPR 5-457
	60,3			RCPR 3-460,3	RCPR 4-460,3	RCPR 5-460,3
	63			RCPR 3-463	RCPR 4-463	RCPR 5-463
	65			RCPR 3-465	RCPR 4-465	RCPR 5-465
70	RCPR 3-470	RCPR 4-470	RCPR 5-470			

Werden andere Kombinationen benötigt, so bestellen Sie diese bitte in Einzelteilen (Bestellzeichen hierfür siehe Seiten 38 – 42). Die Auslieferung erfolgt unmontiert in Einzelteilen. ¹⁾Nur in Größen 1 – 8 ³⁾Bei Montage von Vollgummi-Schellen sind Deckplatten, Sechskantschrauben und Sicherungsscheiben zu verwenden

If different combinations are required, we would be obliged if they could be ordered as separate components (Please refer to individual components, pages 38 – 42). Delivery in unassembled individual components. ¹⁾Only sizes 1 – 8 ³⁾When assembling solid rubber tube clamps, cover plates, hexagon screws and locking washers must be used

Bestellzeichen für Schellenhälften:

Polypropylen **RCPR**
 innen glatt **RCPG¹⁾**
 Polyamid 6 **RCNR**
 innen glatt **RCNG¹⁾**
 Vollgummi **RCVR^{1) 3)}**
RCVG^{1) 3)}
 Aluminium **RCAR**

Bei Bedarf Standardkurzzeichen RCPR in der Spalte „Bestellzeichen“ austauschen.

Order codes for clamp-halves:

Polypropylene **RCPR**
 inside smooth **RCPG¹⁾**
 Polyamide 6 **RCNR**
 inside smooth **RCNG¹⁾**
 Rubber **RCVR^{1) 3)}**
RCVG^{1) 3)}
 Aluminium **RCAR**

Replace standard abbreviation RCPR in column "Order codes" as required.

2 Schellenhälften mit Tragschienen-Muttern, Deckplatte und Sechskantschrauben
 2 clamp halves with rail nut, cover plate and hexagon head screws



2 Schellenhälften mit Tragschienen-Muttern, Deckplatte und Innensechskantschrauben
 2 clamp halves with rail nut, cover plate and hexagon socket head screws



2 Schellenhälften mit Aufbauschrauben und Sicherungsplatte
 2 clamp halves with stacking bolts and locking plate

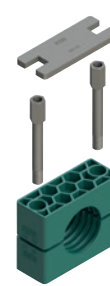

GRÖSSE SIZE	Rohr-AD mm O.D. mm	Rohr-NW Tube NB	Rohr-AD Zoll Inch O.D.	Bestellzeichen Order Codes	Bestellzeichen Order Codes	Bestellzeichen Order Codes
5	65	G 2½	3			RCPR 5-565
	70					RCPR 5-570
	73					RCPR 5-573
	75					RCPR 5-575
	76,1					RCPR 5-576,1
	80	RCPR 5-580				
	82,5	RCPR 5-582,5				
	85	RCPR 5-585				
6	88,9	G 3	3½			RCPR 5-588,9
	90					RCPR 5-590
	90					RCPR 5-690
	97					RCPR 5-697
7	100	G 3½	4			RCPR 5-6100
	101,6					RCPR 5-6101,6
	108					RCPR 5-6108
	114,3	RCPR 5-6114,3				
	127	RCPR 5-6127				
8	127	G 5	5			RCPR 5-7127
	130					RCPR 5-7130
	133					RCPR 5-7133
	140					RCPR 5-7140
	150	G 6	6			RCPR 5-7150
	152,4					RCPR 5-7152,4
	159					RCPR 5-7159
165,1	G 6	8			RCPR 5-7165,1	
168,3					RCPR 5-7168,3	
168,3					RCPR 5-8168,3	
177,8					RCPR 5-8177,8	
193,7	G 8	8			RCPR 5-8193,7	
203					RCPR 5-8203	
219,1					RCPR 5-8219,1	
220			RCPR 5-8220			

Werden andere Kombinationen benötigt, so bestellen Sie diese bitte in Einzelteilen (Bestellzeichen hierfür siehe Seiten 38 – 42). Die Auslieferung erfolgt unmontiert in Einzelteilen. ¹⁾Nur in Größen 1 – 8 ³⁾Bei Montage von Vollgummi-Schellen sind Deckplatten, Sechskantschrauben und Sicherungsscheiben zu verwenden
 If different combinations are required, we would be obliged if they could be ordered as separate components (Please refer to individual components, pages 38 – 42). Delivery in unassembled individual components. ¹⁾Only sizes 1 – 8 ³⁾When assembling solid rubber tube clamps, cover plates, hexagon screws and locking washers must be used

ROHRSCHELLEN SERIE C | KOMPLETT-PROGRAMM

TUBE CLAMPS SERIES C | COMPLETE RANGE

Bestellzeichen

für Schellenhälften:

Polypropylen **RCPR**
 innen glatt **RCPG¹⁾**
 Polyamid 6 **RCNR**
 innen glatt **RCNG¹⁾**
 Vollgummi **RCVR^{1) 3)}**
RCVG^{1) 3)}
 Aluminium **RCAR**

Bei Bedarf Standardkurzzeichen RCPR in der Spalte „Bestellzeichen“ austauschen.

Order codes

for clamp-halves:

Polypropylene **RCPR**
 inside smooth **RCPG¹⁾**
 Polyamide 6 **RCNR**
 inside smooth **RCNG¹⁾**
 Rubber **RCVR^{1) 3)}**
RCVG^{1) 3)}
 Aluminium **RCAR**

Replace standard abbreviation RCPR in column "Order codes" as required.

4 Schellenhälften mit Doppelanschweißplatte, Doppel-Deckplatte und Sechskantschrauben
 4 clamp halves with double weld plate, double cover plate and hexagon head screws



4 Schellenhälften mit Doppelanschweißplatte, Doppel-Deckplatte und Innensechskantschrauben
 4 clamp halves with double weld plate, double cover plate and hexagon socket head screws



GRÖSSE SIZE	Rohr-AD mm O.D. mm	Rohr-NW Tube NB	Rohr-AD Zoll Inch O.D.	Bestellzeichen Order Codes	Bestellzeichen Order Codes
1	6	G 1/8	5/16 3/8	RCPDR 1-106	RCPDR 2-106
	8			RCPDR 1-108	RCPDR 2-108
	9,5			RCPDR 1-109,5	RCPDR 2-109,5
	10	G 1/4	1/2	RCPDR 1-110	RCPDR 2-110
	12			RCPDR 1-112	RCPDR 2-112
	12,7			RCPDR 1-112,7	RCPDR 2-112,7
	13,5			RCPDR 1-113,5	RCPDR 2-113,5
	14	G 3/8	5/8	RCPDR 1-114	RCPDR 2-114
	15			RCPDR 1-115	RCPDR 2-115
	16			RCPDR 1-116	RCPDR 2-116
	17,2			RCPDR 1-117,2	RCPDR 2-117,2
18	RCPDR 1-118			RCPDR 2-118	
2	19	G 1/2	3/4	RCPDR 1-219	RCPDR 2-219
	20			RCPDR 1-220	RCPDR 2-220
	21,3			RCPDR 1-221,3	RCPDR 2-221,3
	22			RCPDR 1-222	RCPDR 2-222
	23	G 3/4	1	RCPDR 1-223	RCPDR 2-223
	25			RCPDR 1-225	RCPDR 2-225
	25,4			RCPDR 1-225,4	RCPDR 2-225,4
	26,9			RCPDR 1-226,9	RCPDR 2-226,9
	28			RCPDR 1-228	RCPDR 2-228
	30			RCPDR 1-230	RCPDR 2-230
3	30	G 1	1 1/4	RCPDR 1-330	RCPDR 2-330
	32			RCPDR 1-332	RCPDR 2-332
	33,7			RCPDR 1-333,7	RCPDR 2-333,7
	35	G 1 1/4	1 1/2	RCPDR 1-335	RCPDR 2-335
	38			RCPDR 1-338	RCPDR 2-338
	40			RCPDR 1-340	RCPDR 2-340
42			RCPDR 1-342	RCPDR 2-342	
4	38	G 1 1/4	1 1/2	RCPDR 1-438	RCPDR 2-438
	40			RCPDR 1-440	RCPDR 2-440
	42			RCPDR 1-442	RCPDR 2-442
	45	G 1 1/2	2	RCPDR 1-445	RCPDR 2-445
	48,3			RCPDR 1-448,3	RCPDR 2-448,3
	50			RCPDR 1-450	RCPDR 2-450
	51			RCPDR 1-451	RCPDR 2-451
	52	G 2	2 1/4	RCPDR 1-452	RCPDR 2-452
	55			RCPDR 1-455	RCPDR 2-455
	57			RCPDR 1-457	RCPDR 2-457
	60,3			RCPDR 1-460,3	RCPDR 2-460,3
	63			RCPDR 1-463	RCPDR 2-463
	65	2 1/2		RCPDR 1-465	RCPDR 2-465
70	RCPDR 1-470			RCPDR 2-470	

Werden andere Kombinationen benötigt, so bestellen Sie diese bitte in Einzelteilen (Bestellzeichen hierfür siehe Seiten 38 – 42). Die Auslieferung erfolgt unmontiert in Einzelteilen. ¹⁾Nur in Größen 1 – 8 ³⁾Bei Montage von Vollgummi-Schellen sind Deckplatten, Sechskantschrauben und Sicherungsscheiben zu verwenden

If different combinations are required, we would be obliged if they could be ordered as separate components (Please refer to individual components, pages 38 – 42). Delivery in unassembled individual components. ¹⁾Only sizes 1 – 8 ³⁾When assembling solid rubber tube clamps, cover plates, hexagon screws and locking washers must be used

Bestellzeichen

für Schellenhälften:

Polypropylen **RCPR**
 innen glatt **RCPG¹⁾**
 Polyamid 6 **RCNR**
 innen glatt **RCNG¹⁾**
 Vollgummi **RCVR^{1) 3)}**
RCVG^{1) 3)}
 Aluminium **RCAR**

Bei Bedarf Standardkurzzeichen RCPR in der Spalte „Bestellzeichen“ austauschen.

Order codes

for clamp-halves:

Polypropylene **RCPR**
 inside smooth **RCPG¹⁾**
 Polyamide 6 **RCNR**
 inside smooth **RCNG¹⁾**
 Rubber **RCVR^{1) 3)}**
RCVG^{1) 3)}
 Aluminium **RCAR**

Replace standard abbreviation RCPR in column "Order codes" as required.

4 Schellenhälften mit Doppelansweißplatte, Doppel-Deckplatte und Sechskantschrauben
 4 clamp halves with double weld plate, double cover plate and hexagon head screws



4 Schellenhälften mit Doppelansweißplatte, Doppel-Deckplatte und Innensechskantschrauben
 4 clamp halves with double weld plate, double cover plate and hexagon socket head screws



GRÖSSE SIZE	Rohr-AD mm O.D. mm	Rohr-NW Tube NB	Rohr-AD Zoll Inch O.D.	Bestellzeichen Order Codes	Bestellzeichen Order Codes
5	65	G 2 1/2	2 3/4	RCPDR 1-565	RCPDR 2-565
	70			RCPDR 1-570	RCPDR 2-570
	73			RCPDR 1-573	RCPDR 2-573
	75			RCPDR 1-575	RCPDR 2-575
	76,1	G 3	3	RCPDR 1-576,1	RCPDR 2-576,1
	80			RCPDR 1-580	RCPDR 2-580
	82,5			RCPDR 1-582,5	RCPDR 2-582,5
	85			RCPDR 1-585	RCPDR 2-585
88,9	G 3	3 1/2	RCPDR 1-588,9	RCPDR 2-588,9	
90			RCPDR 1-590	RCPDR 2-590	
6	90	G 3 1/2	4	RCPDR 1-690	RCPDR 2-690
	97			RCPDR 1-697	RCPDR 2-697
	100			RCPDR 1-6100	RCPDR 2-6100
	101,6			RCPDR 1-6101,6	RCPDR 2-6101,6
	108	G 4	4 1/2	RCPDR 1-6108	RCPDR 2-6108
	114,3			RCPDR 1-6114,3	RCPDR 2-6114,3
127	G 4	5	RCPDR 1-6127	RCPDR 2-6127	
7	127	G 5	5	RCPDR 1-7127	RCPDR 2-7127
	130			RCPDR 1-7130	RCPDR 2-7130
	133			RCPDR 1-7133	RCPDR 2-7133
	140			RCPDR 1-7140	RCPDR 2-7140
	150	G 6	6	RCPDR 1-7150	RCPDR 2-7150
	152,4			RCPDR 1-7152,4	RCPDR 2-7152,4
	159			RCPDR 1-7159	RCPDR 2-7159
	165,1			RCPDR 1-7165,1	RCPDR 2-7165,1
168,3	G 6	8	RCPDR 1-7168,3	RCPDR 2-7168,3	
168,3			RCPDR 1-8168,3	RCPDR 2-8168,3	
177,8	G 8	8	RCPDR 1-8177,8	RCPDR 2-8177,8	
193,7			RCPDR 1-8193,7	RCPDR 2-8193,7	
203			RCPDR 1-8203	RCPDR 2-8203	
219,1			RCPDR 1-8219,1	RCPDR 2-8219,1	
220			RCPDR 1-8220	RCPDR 2-8220	
219,1			G 8		RCPDR 1-9219,1
244,5	RCPDR 1-9244,5	RCPDR 2-9244,5			
273	RCPDR 1-9273	RCPDR 2-9273			
323,9	RCPDR 1-9323,9	RCPDR 2-9323,9			
10	355,6	G 14		RCPDR 1-10355,6	RCPDR 2-10355,6
	406,4	G 16		RCPDR 1-10406,4	RCPDR 2-10406,4

Werden andere Kombinationen benötigt, so bestellen Sie diese bitte in Einzelteilen (Bestellzeichen hierfür siehe Seiten 38 – 42). Die Auslieferung erfolgt unmontiert in Einzelteilen. ¹⁾Nur in Größen 1 – 8 ³⁾Bei Montage von Vollgummi-Schellen sind Deckplatten, Sechskantschrauben und Sicherungsscheiben zu verwenden

If different combinations are required, we would be obliged if they could be ordered as separate components (Please refer to individual components, pages 38 – 42). Delivery in unassembled individual components. ¹⁾Only sizes 1 – 8 ³⁾When assembling solid rubber tube clamps, cover plates, hexagon screws and locking washers must be used

// 04

DOPPELSCHELLE SCHWERE BAUREIHE

TWIN CLAMP HEAVY SERIES

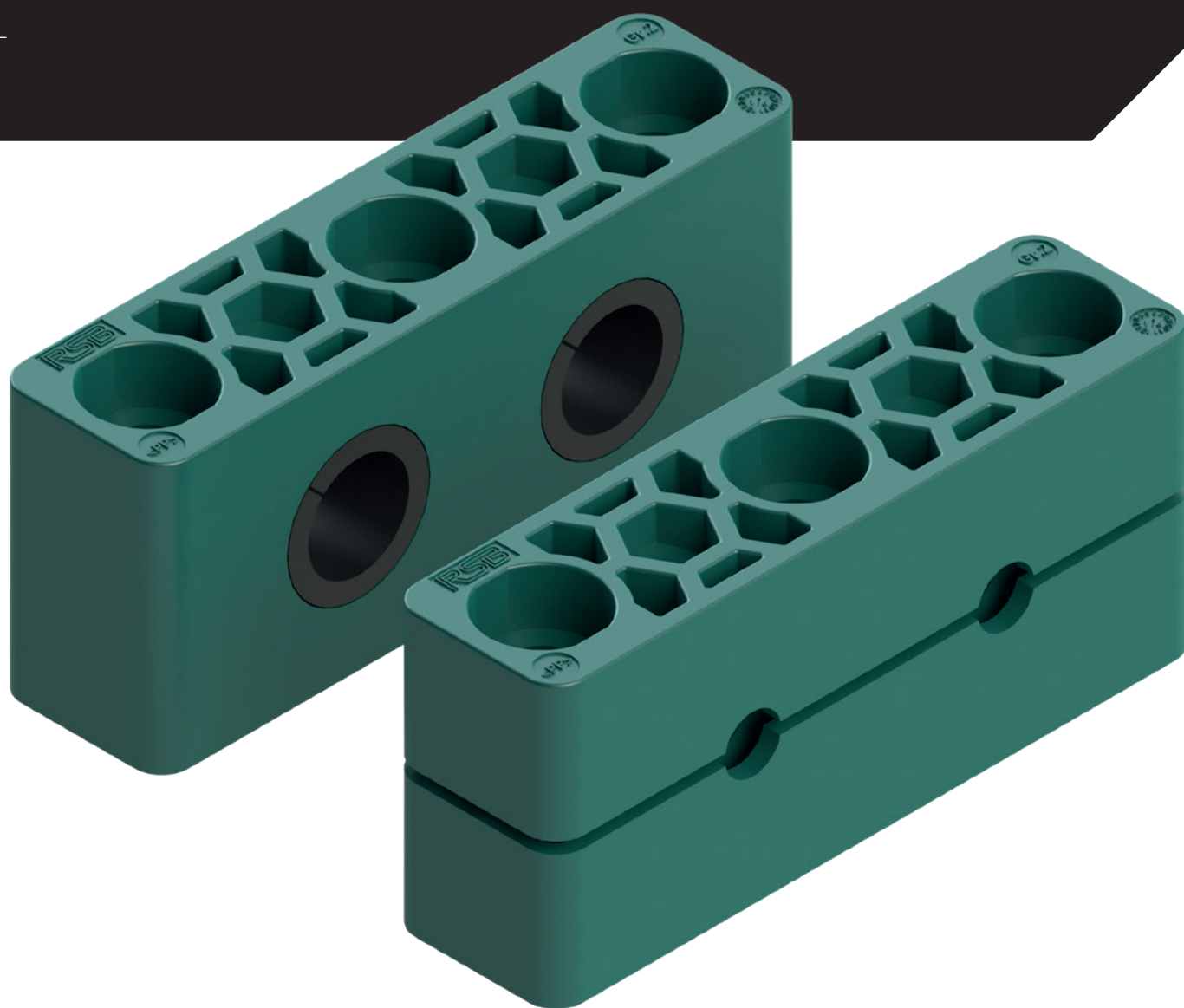

DOPPELSCHELLE SCHWERE BAUREIHE TWIN CLAMP HEAVY SERIES

Bestellzeichen für Schellenhälften:

Polypropylen **RCPRD**
Polyamid 6 **RCNRD**

Bei Bedarf Standardkurzzeichen RCPRD in der Spalte „Schellenhälften“ austauschen.

Order codes for clamp-halves:

Polypropylene **RCPRD**
Polyamide 6 **RCNRD**

Replace standard abbreviation RCPRD in column "clamp-halves" as required.

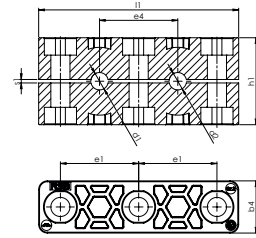

GRÖSSE SIZE	Rohr-AD mm O.D. mm	Rohr-NW Tube NB	Rohr-AD Zoll Inch O.D.	RCPRD 1 Stück / 2 Schellenhälften 1 part / 2 clamp-halves	RCPRD-...					
	d ₁ / d ₂				l ₁	h ₁	e ₁	e ₄	s ₁	b ₄
2	10	G 1/8		RCPRD-210	115	50	45	45	2	30
	12,7		1/2	RCPRD-212,7						
	19		3/4	RCPRD-219						
	20			RCPRD-220						
	21,3	G 1/2		RCPRD-221,3						
	22			RCPRD-222						
	25,4		1	RCPRD-225,4						
	26,9	G 3/4		RCPRD-226,9						
	28			RCPRD-228						
30			RCPRD-230	145	60	60	60	2	30	
30			RCPRD-330							
32		1 1/4	RCPRD-332							
33,7	G 1		RCPRD-333,7							
35			RCPRD-335							
38		1 1/2	RCPRD-338							
40			RCPRD-340							
42	G 1 1/4		RCPRD-342							

Rohrschellen mit unterschiedlichen Rohr-AD auf Anfrage.

Tube clamps with different outer tube diameter upon request.

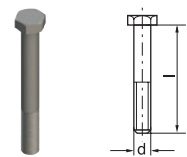
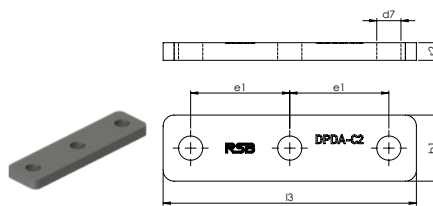
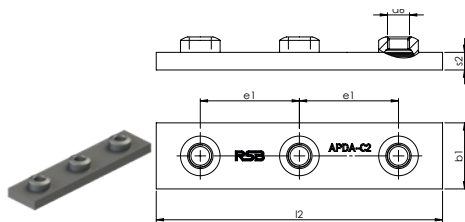

DIN 931/933

GRÖSSE SIZE	APDA-C Anschweißplatte Weld plate	APDA-C					DPDA-C Deckplatte Cover plate	DPDA-C					SS-C Sechskantschraube Hexagon head screw	SS-C		
		e ₁	b ₁	l ₂	s ₂	d ₆		l ₃	e ₁	b ₁	s ₂	d ₇		d	x	l
2	APDA-C2	45	30	130	8	M10	DPDA-C2	115	45	30	8	11	SS-C2	M10	x	60
3	APDA-C3	60	30	160	8	M10	DPDA-C3	145	60	30	8	11	SS-C3	M10	x	70

Außerdem passend für die Doppelschelle Schwere Baureihe:
 - Innensechskantschraube IS-C (Schwere Baureihe, Größe 2 und 3)
 - Befestigungsadapter BA (Schwere Baureihe, Größe 2 und 3)
 - Tragschienenmutter TM-C (Schwere Baureihe, Größe 2 und 3)
 - Tragschiene TS-C (Schwere Baureihe)
 - Aufbauschraube AS-C (Schwere Baureihe, Größe 2 und 3)
 - Sicherungsplatte SPD-C (Schwere Baureihe, Doppelausführung)

Also suitable for twin clamp heavy series:
 - Hexagon socket head screw IS-C (heavy series, size 2 and 3)
 - Fixed adaptor BA (heavy series, size 2 and 3)
 - Rail nut TM-C (heavy series, size 2 and 3)
 - Mounting rail TS-C (heavy series)
 - Stacking bolt AS-C (heavy series, size 2 and 3)
 - Locking plate SPD-C (heavy series, twin version)



Metallteile in Edelstahl lieferbar.

All metal parts available in stainless steel.

DOPPELSHELLE SCHWERE BAUREIHE
TWIN CLAMP HEAVY SERIES

Bestellzeichen für Schellenhälften:

Polypropylen **RCPEED**
Polyamid 6 **RCNEED**

Bei Bedarf Standardkurzzeichen RCPEED in der Spalte „Schellenhälften“ austauschen.

Order codes for clamp-halves:

Polypropylene **RCPEED**
Polyamide 6 **RCNEED**

Replace standard abbreviation RCPEED in column "clamp-halves" as required.

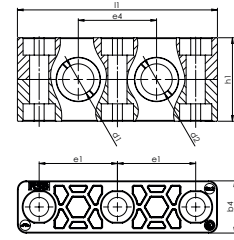
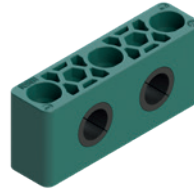

GRÖSSE SIZE	Rohr-AD mm O.D. mm	Rohr-NW Tube NB	Rohr-AD Zoll Inch O.D.	RCPEED 1 Stück / 2 Schellenhälften 1 part / 2 clamp-halves	RCPEED-... 2 Schellenhälften 2 clamp-halves				
	d ₁ / d ₂				l ₁	h ₁	e ₁	e ₄	b ₄
2	6			RCPEED-206	115	48	45	45	30
	8		⁵ / ₁₆	RCPEED-208					
	10	G ¹ / ₈		RCPEED-210					
	12			RCPEED-212					
	12,7		¹ / ₂	RCPEED-212,7					
	14			RCPEED-214					
	15			RCPEED-215					
	16		⁵ / ₈	RCPEED-216					
	17,2	G ³ / ₈		RCPEED-217,2					
	18			RCPEED-218					
	19		³ / ₄	RCPEED-219	145	58	60	60	30
3	20			RCPEED-320					
	21,3	G ¹ / ₂		RCPEED-321,3					
	22			RCPEED-322					
	23			RCPEED-323					
	25			RCPEED-325					
	26,9	G ³ / ₄		RCPEED-326,9					
	28			RCPEED-328					
	30			RCPEED-330					
	32		¹ / ₄	RCPEED-332					

Rohrschellen mit Einsätzen für unterschiedliche Rohr-AD auf Anfrage.

Tube clamps with inserts for different outer tube diameter upon request.

DOPPELSCHELLE SCHWERE BAUREIHE
TWIN CLAMP HEAVY SERIES

Bestellzeichen für Schellenhälften:

Polypropylen **RCPED**
 Polyamid 6 **RCNED**

Bei Bedarf Standardkurzzeichen RCPED in der Spalte „Schellenhälften“ austauschen.

Order codes for clamp-halves:

Polypropylene **RCPED**
 Polyamide 6 **RCNED**

Replace standard abbreviation RCPED in column "clamp-halves" as required.

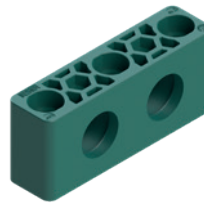

GRÖSSE SIZE	Rohr-AD mm O.D. mm d₁ / d₂	Rohr-NW Tube NB	Rohr-AD Zoll Inch O.D.	RCPED Schellenkörper für Einlage Tube clamp suitable for insert	EE-... Schalldämmeinlage Noise protection insert
2	6			RCPED-2	EE-206/406
	8		⁵ / ₁₆		EE-208/408
	10	G ¹ / ₈			EE-210/410
	12				EE-212/412
	12,7		¹ / ₂		EE-212,7/412,7
	14				EE-214/414
	15				EE-215/415
	16		⁵ / ₈		EE-216/416
	17,2	G ³ / ₈			EE-217,2/417,2
	18				EE-218/418
	19		³ / ₄		EE-219/419
3	20			RCPED-3	EE-320/620
	21,3	G ¹ / ₂			EE-321,3/621,3
	22				EE-322/622
	23				EE-323/623
	25				EE-325/625
	26,9	G ³ / ₄			EE-326,9/626,9
	28				EE-328/628
	30				EE-330/630
	32		1 ¹ / ₄		EE-332/632

// 04

BEFESTIGUNGSADAPTER

FIXED ADAPTOR

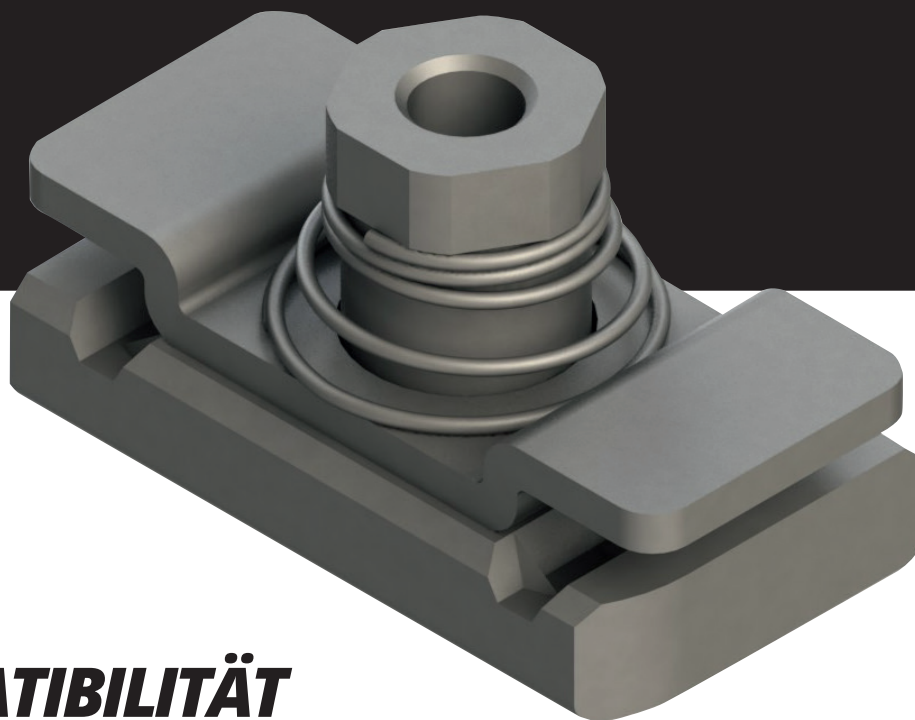

// KOMPATIBILITÄT

MIT PROFILSCHIENEN

// COMPATIBILITY

WITH CHANNEL RAILS

HILTI <i>(Schiensystem MQ für mittlere Belastung Channel system MQ for medium load)</i>	HALFEN <i>(Mittelschwere Tragsysteme Medium duty channel system)</i>	UNISTRUT®
MQ-21, MQ-21U, MQ-21D	HM 41/22, HL 41/22, HM 41/22 D	P1000, P1000T, P1001, P1001T
MQ-31,	HZM 41/22, HZL 41/22, HZM 41/22 D	P2000, P2000T
MQ-41, MQ-41U, MQ-41D	HM 41/41, HL 41/41, HM 41/41 D	P3300, P3300T10, P3301, P3301T10
MQ-52, MQ-52-72D	HZM 41/41, HZL 41/41, HZM 41/41 D	P4000, P4000T10
MQ-72, MQ-72U	HM 41/62, HL 41/62, HM 41/62 D	P5000T, P5001T, P5500T, P5501T
	HM 41/83, HL 41/83	

Zur Überprüfung der Kompatibilität mit Profilschienen anderer Hersteller wenden Sie sich bitte vor Anwendung an uns.
Please contact us to check compatibility with additional types of channel rails.



// BEFESTIGUNGSADAPTER FÜR SERIE A

// FIXED ADAPTOR FOR SERIES A

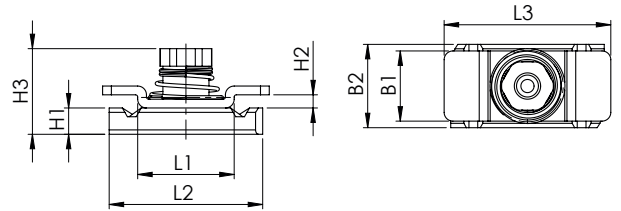
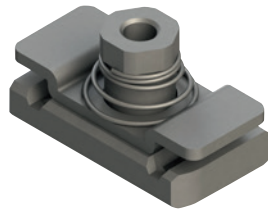

GRÖSSE SIZE	BA Befestigungsadapter Fixed adaptor									
	L1	L2	L3	B1	B2	H1	H2	H3	d6	
1	BA-A/B1	22	35	38	16	19	6	3	19,5	M6
2										
3										
4										
5										
6										
7										
8										

// BEFESTIGUNGSADAPTER FÜR SERIE B

// FIXED ADAPTOR FOR SERIES B

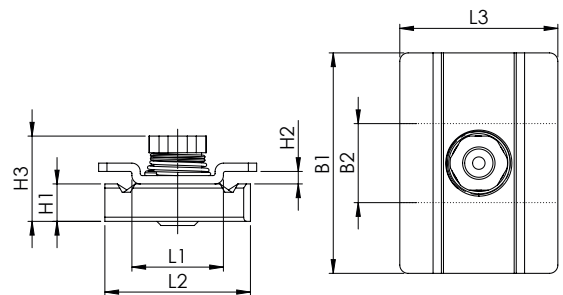
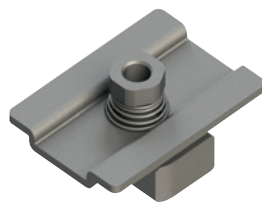

GRÖSSE SIZE	BA Befestigungsadapter Fixed adaptor									
	L1	L2	L3	B1	B2	H1	H2	H3	d6	
1	22	35	38	16	19	6	3	19,5	M6	
2				53						
3				80						
4				80						
5				80						

Lieferbar: verzinkt und Edelstahl
 Auch in UNC erhältlich
 Available: galvanized and stainless steel
 Also available in UNC



// BEFESTIGUNGSADAPTER FÜR SERIE C

// FIXED ADAPTOR FOR SERIES C

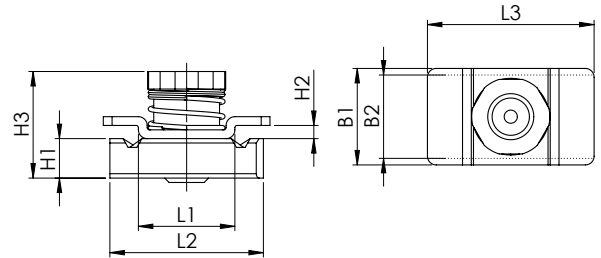
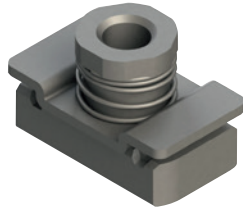

GRÖSSE SIZE	BA Befestigungsadapter Fixed adaptor									
	L1	L2	L3	B1	B2	H1	H2	H3	d6	
1	22	35	38	22	19	9	3	24,3	M10	
2										
3										
4	BA-C4			45	25			25,8	M12	

// EMPFOHLENE SCHRAUBENLÄNGEN

BEI VERWENDUNG DES BEFESTIGUNGSADAPTERS BA FÜR DIE C-SERIE

// RECOMMENDED SCREW LENGTHS

WHEN USING FIXED ADAPTOR BA FOR SERIES C

GRÖSSE SIZE	Sechskantschraube (mit Deckplatte) Hexagon head screw (with cover plate)	Innensechskantschraube (ohne Deckplatte) Hexagon socket head screw (without cover plate)	Aufbauschraube Stacking bolt
1	M10 x 40	M10 x 20 *	M10 x 20 *
2	M10 x 55 *	M10 x 35 *	M10 x 35 *
3	M10 x 65 *	M10 x 50 *	M10 x 50 *
4	M12 x 100	M12 x 75 *	M12 x 75 *

* bei Schrauben mit Sonderlängen (abweichend vom Katalog) Preis auf Anfrage
 * for screws with special length (different from the catalogue) price on request

Lieferbar: verzinkt und Edelstahl
 Auch in UNC erhältlich
 Available: galvanized and stainless steel
 Also available in UNC



// GENERALE MASSLICHE ANFORDERUNGEN

AN PROFILSCHIENEN FÜR DEN EINSATZ DES BEFESTIGUNGSADAPTERS BA

// BASIC DIMENSIONAL REQUIREMENTS

FOR CHANNEL RAILS TO BE USED WITH FIXED ADAPTOR BA

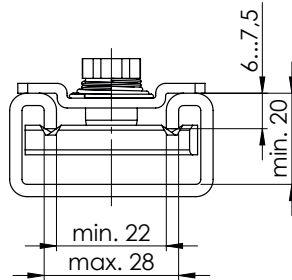

// BESTELLBEISPIEL

BA-A/B1/Zn
 BA-B2-3/Mat.A4
 BA-C1-3/Zn/UNC

BA - **A/B1** / **Zn**

Serie
 A/B1
 B2-3
 B4-5
 C1-3
 C4

Merkmale
 Zn=verzinkt
 Mat.A4=Edelstahl A4
 UNC=UNC-Gewinde

BA=Befestigungsadapter

// EXAMPLE OF ORDER

BA-A/B1/Zn
 BA-B2-3/Mat.A4
 BA-C1-3/Zn/UNC

BA - **A/B1** / **Zn**

Serie
 A/B1
 B2-3
 B4-5
 C1-3
 C4

Features
 Zn= zinc plated
 Mat.A4= stainless steel A4
 UNC= UNC thread

BA=Fixed adaptor

UNBEGRENZTE MÖGLICHKEITEN: EINE SCHIENE FÜR ALLE

MONTAGE VON ELEMENTEN DER SERIE A, B UND C AUF TS-C SCHIENE

UNLIMITED POSSIBILITIES:

ONE MOUNTING RAIL FOR ALL

**ASSEMBLY OF SERIES A, B AND C COMPONENTS
ON TS-C MOUNTING RAIL**

Konstruktion

Neue Tragschienen-Muttern ermöglichen eine Montage der Rohrschellen unserer Serie A-, B- und C-Standardausführung auf Montageschienen der schweren Baureihe C.

VORTEIL FÜR SIE

Kombinieren Sie bewährte Elemente unserer verschiedenen Baureihen für eine Vielzahl neuer Anwendungsmöglichkeiten:

EINE SCHIENE, MEHR FUNKTION!

Alle Metallteile auch in Edelstahl.

Design

New mounting rail-nuts make it possible to mount standard tube clamps of our series A, B and C, on the heavy duty mounting rail, series C.

YOUR ADVANTAGE

Combine reliable and field-tested components of our various series for a multitude of new applicability:

ONE MOUNTING RAIL – MORE FUNCTIONS!

Also available in stainless steel.

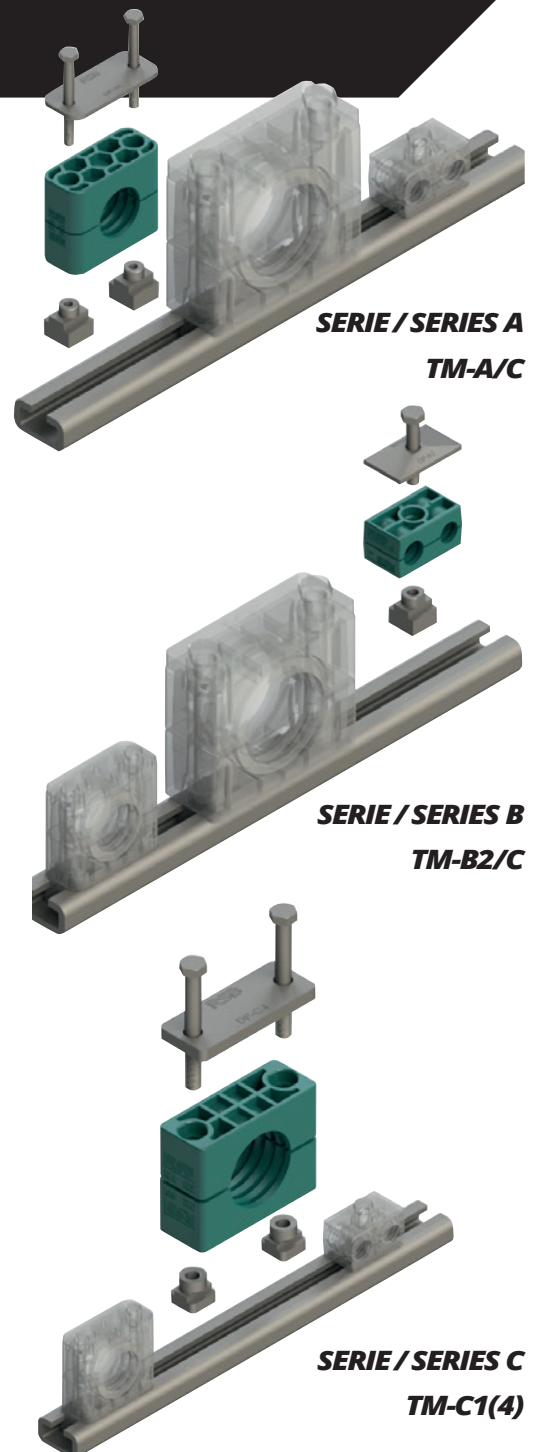

// TRAGSCHIENEN-MUTTERN // RAIL NUTS

Der einfachste Weg Rohrschellen DIN 3015 auf einer Tragschiene unserer schweren Baureihe zu montieren.

- Leichte Baureihe - Serie A
- Zweirohrschele - Serie B
- Schwere Baureihe - Serie C

Bestellzeichen:
TM-A/C
TM-B2/C
TM-C1
TM-C4

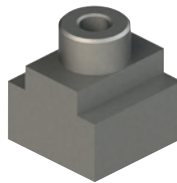

TM-A/C

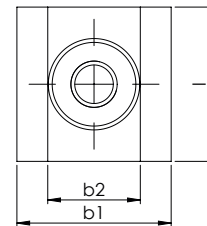
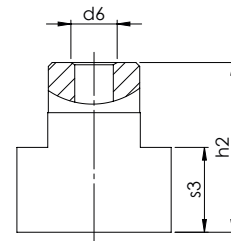

The easiest way to mount DIN 3015 tube clamps on a rail of our heavy duty series.

- Light construction - Series A
- Twin-tube clamps - Series B
- Heavy duty construction - Series C

Order codes:
TM-A/C
TM-B2/C
TM-C1
TM-C4

Für Schellen Serie For clamps series	Bestellzeichen Order codes	d ₆	l	b ₁	b ₂	h ₂	s ₃
A / B1	TM-A/C	M 6	20	20	12	22	11
B2 - B5	TM-B2/C	M 8	20	20	12	22	11
C1 - C3	TM-C1	M 10	25	24	12	20	7
C4	TM-C4	M 12	25	24	12,5	23	8,5

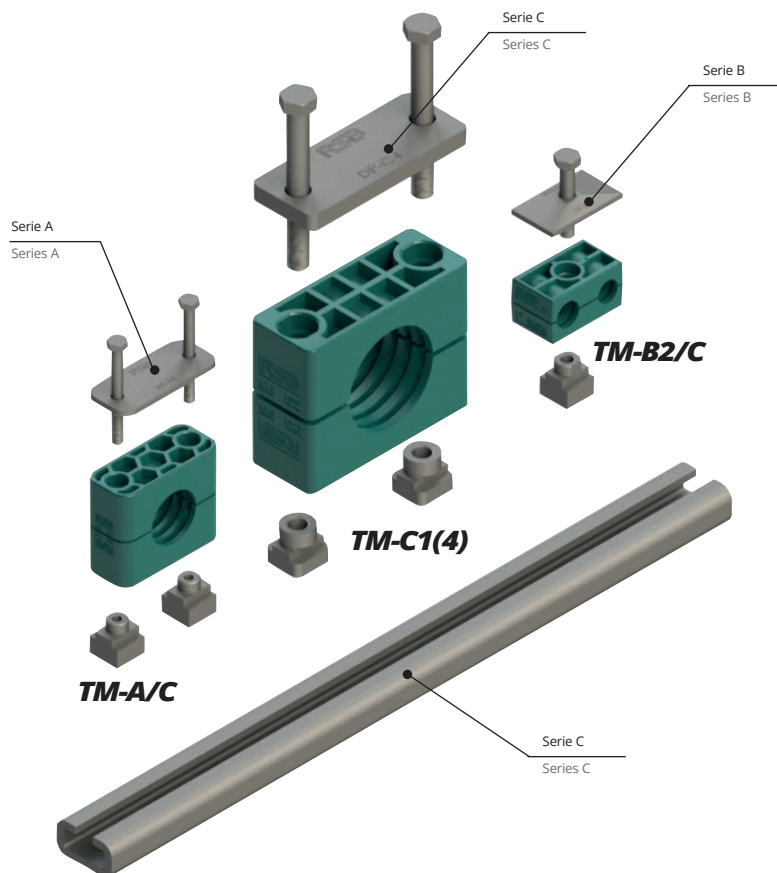

MONTAGEBEISPIELE MIT TRAGSCHIENEN

**EXAMPLES FOR THE ASSEMBLY
WITH MOUNTING RAILS**

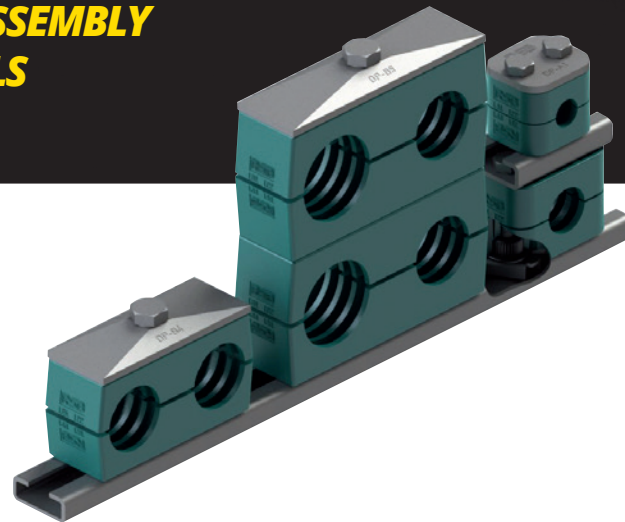

*EINFACHE MONTAGE
INDIVIDUELLE ZUSAMMENSTELLUNGEN
VIELSEITIGE EINSETZBARKEIT*

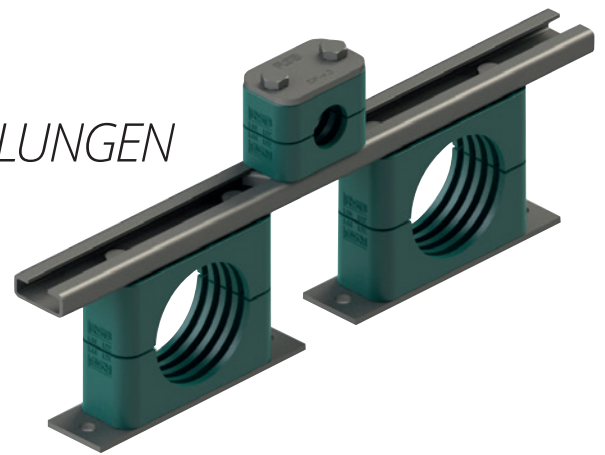

*EASILY ASSEMBLED
INDIVIDUAL COMBINATION
VERSATILE APPLICATION*

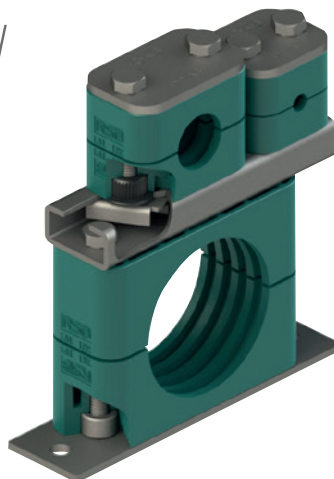

// 05

ROHRSCHELLEN MIT SCHALLDÄMMEINLAGE

TUBE CLAMPS WITH NOISE PROTECTION INSERT

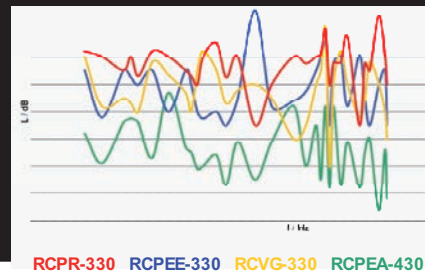

RCPR-330 RCPEE-330 RCVG-330 RCPEA-430

Vergleich des Dämmungsverhalten verschiedener Rohrschellen (schematisch)
Comparison of the noise insulation properties of different tube clamps (schematic)

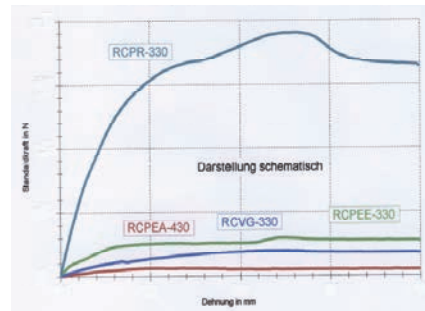

Vergleich der axialen Rohrhaltekraft verschiedener Rohrschellen
Comparison of the pipe shearing force of different tube clamps

**VIBRATIONSDÄMMUNG UND KÖRPERSCHALLENTKOPPLUNG IM SYSTEM
FÜR JEDE ANWENDUNG DIE RICHTIGE LÖSUNG!**

*THE SYSTEM FOR VIBRATION INSULATION AND STRUCTURE-BORNE NOISE INSULATION
THE SUITABLE SOLUTION FOR EACH APPLICATION!*

Die Herstellung lärmarmer Maschinen, Geräte und Anlagen gewinnt durch das wachsende Umweltbewusstsein immer mehr an Bedeutung.

Mit unserem Schalldämmungssystem

- Schellenkörper **vollelastisch** aus TPE
 - Rohrschellen mit **Schalldämmeinlage EE/TPE**
 - Rohrschellen mit **Schalldämmeinlage EFA/TPE**
- decken Sie alle Anwendungsbereiche ab.

The production of quiet machines, devices and equipment becomes more and more important due to the growing environmental awareness.

With our noise protection system

- **Fully flexible tube clamps TPE**
 - **Tube clamps with noise protection insert EE/TPE**
 - **Tube clamps with noise protection insert EFA/TPE**
- you cover all fields of applications.

// LEICHTBAUREIHE
// LIGHT CONSTRUCTIONS SERIES



SCHALLDÄMMEINLAGE
NOISE PROTECTION INSERT

Bestellzeichen für Schellenhälften:
 Polypropylen **RAPE**
 Polyamid 6 **RANE**

Bei Bedarf Standardkurzzeichen RAPE oder RAPEE in der Spalte „Serie A“ austauschen.

Order codes for clamp-halves:
 Polypropylene **RAPE**
 Polyamide 6 **RANE**

Replace standard abbreviation RAPE or RAPEE in column "Series A" as required.

Bestellzeichen für Schalldämmeinlage:
EE-*

mit Schellengröße und Rohraußendurchmesser ergänzen, TPE 73° Shore

Order codes for noise protection insert:
EE-*

complete with clamp size and outside tube diameter, TPE 73° Shore

GRÖSSE SIZE SERIE A / SERIES A	Rohr-AD mm O.D. mm	SERIE A / SERIES A		Schalldämmeinlage Noise protection insert
		Schellenkörper für Einlage Tube clamp suitable for insert	Schellenkörper mit Schalldämmeinlage Tube clamp with noise protection insert	
4	6	RAPE-4	RAPEE-406	EE-206/406
	8		RAPEE-408	EE-208/408
	10		RAPEE-410	EE-210/410
	12		RAPEE-412	EE-212/412
	12,7		RAPEE-412,7	EE-212,7/412,7
	14		RAPEE-414	EE-214/414
	15		RAPEE-415	EE-215/415
	16		RAPEE-416	EE-216/416
	17,2		RAPEE-417,2	EE-217,2/417,2
	18		RAPEE-418	EE-218/418
	19		RAPEE-419	EE-219/419
5	20	RAPE-5	RAPEE-520	EE-520
	22		RAPEE-522	EE-522
	25		RAPEE-525	EE-525
	28		RAPEE-528	EE-528
	30		RAPEE-530	EE-530
6	20	RAPE-6	RAPEE-620	EE-320/620
	21,3		RAPEE-621,3	EE-321,3/621,3
	22		RAPEE-622	EE-322/622
	23		RAPEE-623	EE-323/623
	25		RAPEE-625	EE-325/625
	26,9		RAPEE-626,9	EE-326,9/626,9
	28		RAPEE-628	EE-328/628
	30		RAPEE-630	EE-330/630
	32		RAPEE-632	EE-332/632
6	35	RAPAE-6	RAPEE-635	EE-635
	38		RAPEE-638	EE-638
	42		RAPEE-642	EE-642
	45		RAPEE-645	EE-645

Achtung! Bei Schellen mit Schalldämmeinlage ist die Zuordnung von Durchmesser und Baugröße nicht identisch mit der Profil- bzw. glatten Ausführung.
 Attention! For tube clamps with noise protection insert, the relation of diameter and size is not identical with the profile design or smooth design.

// SCHWERE BAUREIHE
// HEAVY SERIES

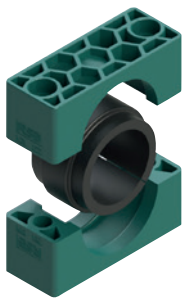

SCHALLDÄMMEINLAGE
NOISE PROTECTION INSERT

Bestellzeichen für Schellenhälften:

Polypropylen **RCPE**
 Polyamid 6 **RCNE**

Bei Bedarf Standardkurzzeichen RCPE oder RCNE in der Spalte „Serie C“ austauschen.

Order codes for clamp-halves:

Polypropylene **RCPE**
 Polyamide 6 **RCNE**

Replace standard abbreviation RCPE or RCNE in column "Series C" as required.

Bestellzeichen für Schalldämmeinlage:
EE-*

mit Schellengröße und Rohraußendurchmesser ergänzen, TPE 73° Shore

Order codes for noise protection insert:
EE-*

complete with clamp size and outside tube diameter, TPE 73° Shore

GRÖSSE SIZE SERIE C / SERIES C	Rohr-AD mm O.D. mm	SERIE C / SERIES C		Schalldämmeinlage Noise protection insert
		Schellenkörper für Einlage Tube clamp suitable for insert	Schellenkörper mit Schalldämmeinlage Tube clamp with noise protection insert	
2	6	RCPE-2	RCPEE-206	EE-206/406
	8		RCPEE-208	EE-208/408
	10		RCPEE-210	EE-210/410
	12		RCPEE-212	EE-212/412
	12,7		RCPEE-212,7	EE-212,7/412,7
	14		RCPEE-214	EE-214/414
	15		RCPEE-215	EE-215/415
	16		RCPEE-216	EE-216/416
	17,2		RCPEE-217,2	EE-217,2/417,2
	18		RCPEE-218	EE-218/418
	19		RCPEE-219	EE-219/419
3	20	RCPE-3	RCPEE-320	EE-320/620
	21,3		RCPEE-321,3	EE-321,3/621,3
	22		RCPEE-322	EE-322/622
	23		RCPEE-323	EE-323/623
	25		RCPEE-325	EE-325/625
	26,9		RCPEE-326,9	EE-326,9/626,9
	28		RCPEE-328	EE-328/628
	30		RCPEE-330	EE-330/630
	32		RCPEE-332	EE-332/632
	4		32	RCPE-4
33,7		RCPEE-433,7	EE-433,7	
35		RCPEE-435	EE-435	
38		RCPEE-438	EE-438	
40		RCPEE-440	EE-440	
42		RCPEE-442	EE-442	
45,5		RCPEE-445,5	EE-445,5	
48		RCPEE-448	EE-448	
51		RCPEE-451	EE-451	
53,4		RCPEE-453,4	EE-453,4	
56,4		RCPEE-456,4	EE-456,4	
60,3	RCPEE-460,3	EE-460,3		

Achtung! Bei Schellen mit Schalldämmeinlage ist die Zuordnung von Durchmesser und Baugröße nicht identisch mit der Profil- bzw. glatten Ausführung.
 Attention! For tube clamps with noise protection insert, the relation of diameter and size is not identical with the profile design or smooth design.

// SCHWERE BAUREIHE
// HEAVY SERIES



SCHALLDÄMMEINLAGE
NOISE PROTECTION INSERT

Bestellzeichen für Schellenhälften:
 Polypropylen **RCPE**
 Polyamid 6 **RCNE**

Bei Bedarf Standardkurzzeichen RCPE oder RCNE in der Spalte „Serie C“ austauschen.

Order codes for clamp-halves:
 Polypropylene **RCPE**
 Polyamide 6 **RCNE**

Replace standard abbreviation RCPE or RCNE in column "Series C" as required.

Bestellzeichen für Schalldämmeinlage:
EE-*

mit Schellengröße und Rohraußendurchmesser ergänzen, TPE 73° Shore

Order codes for noise protection insert:
EE-*

complete with clamp size and outside tube diameter, TPE 73° Shore

GRÖSSE SIZE SERIE C / SERIES C	Rohr-AD mm O.D. mm	SERIE C / SERIES C		Schalldämmeinlage Noise protection insert
		Schellenkörper für Einlage Tube clamp suitable for insert	Schellenkörper mit Schalldämmeinlage Tube clamp with noise protection insert	
5	57	RCPE-5	RCPEE-557	EE-557
	60,3		RCPEE-560,3	EE-560,3
	63,5		RCPEE-563,5	EE-563,5
	65		RCPEE-565	EE-565
	70		RCPEE-570	EE-570
	73		RCPEE-573	EE-573
	76,1		RCPEE-576,1	EE-576,1
6	80	RCPE-6	RCPEE-680	EE-680
	82,5		RCPEE-682,5	EE-682,5
	88,9		RCPEE-688,9	EE-688,9
	100		RCPEE-6100	EE-6100
	101,6		RCPEE-6101,6	EE-6101,6
7	101,6	RCPE-7	RCPEE-7101,6	EE-7101,6
	108		RCPEE-7108	EE-7108
	114,3		RCPEE-7114,3	EE-7114,3
	127		RCPEE-7127	EE-7127
	133		RCPEE-7133	EE-7133

Achtung! Bei Schellen mit Schalldämmeinlage ist die Zuordnung von Durchmesser und Baugröße nicht identisch mit der Profil- bzw. glatten Ausführung.
 Attention! For tube clamps with noise protection insert, the relation of diameter and size is not identical with the profile design or smooth design.

// LEICHTBAUREIHE
// LIGHT CONSTRUCTIONS SERIES



SCHALLDÄMMEINLAGE
NOISE PROTECTION INSERT

Bestellzeichen für Schellenhälften:

Polypropylen **RAPE**
 Polyamid 6 **RANE**

Schellengröße A6 ab Ø 18:

Polypropylen **RAPAE**
 Polyamid 6 **RANAE**

Bei Bedarf Standardkurzzeichen RAPE/RAPAE oder RAPEA in der Spalte „Serie A“ austauschen.

Order codes for clamp-halves:

Polypropylene **RAPE**
 Polyamide 6 **RANE**

Clamp size A6 from Ø 18:

Polypropylene **RAPAE**
 Polyamide 6 **RANAE**

Replace standard abbreviation RAPE or RAPEA in column "Series A" as required.

Bestellzeichen für Schalldämmeinlage:
EFA-*

mit Schellengröße und Rohr-
 außendurchmesser ergänzen,
 TPE 55° Shore

Order codes for noise protection insert:
EFA-*

complete with clamp size and
 outside tube diameter,
 TPE 55° Shore

GRÖSSE SIZE SERIE A / SERIES A	Rohr-AD mm O.D. mm	SERIE A / SERIES A		Schalldämmeinlage Noise protection insert
		Schellenkörper für Einlage Tube clamp suitable for insert	Schellenkörper mit Schalldämmeinlage Tube clamp with noise protection insert	
4	10	RAPE-4	RAPEA-410	EFA-410/210
5	10 12 15	RAPE-5	RAPEA-510 RAPEA-512 RAPEA-515	EFA-510 EFA-512 EFA-515
6	10 12 15 18 20	RAPE-6	RAPEA-610 RAPEA-612 RAPEA-615 RAPEA-618 RAPEA-620	EFA-610/310 EFA-612/312 EFA-615/315 EFA-618/318 EFA-620/320
6	18 20 22 25 28 30	RAPAE-6	RAPEA-618 RAPEA-620 RAPEA-622 RAPEA-625 RAPEA-628 RAPEA-630	EFA-618 EFA-620 EFA-622 EFA-625 EFA-628 EFA-630

Achtung! Bei Schellen mit Schalldämmeinlage ist die Zuordnung von Durchmesser und Baugröße nicht identisch mit der Profil- bzw. glatten Ausführung.
 Attention! For tube clamps with noise protection insert, the relation of diameter and size is not identical with the profile design or smooth design.

// SCHWERE BAUREIHE
// HEAVY SERIES



SCHALLDÄMMEINLAGE
NOISE PROTECTION INSERT

Bestellzeichen
für Schellenhälften:

Polypropylen **RCPE**
Polyamid 6 **RCNE**

Bei Bedarf Standardkurzzeichen
RCPE oder RCNE in der Spalte
„Serie C“ austauschen.

Order codes
for clamp-halves:

Polypropylene **RCPE**
Polyamide 6 **RCNE**

Replace standard abbreviation
RCPE or RCNE in column
"Series C" as required.

Bestellzeichen
für Schalldämmeinlage:

EFA-*

mit Schellengröße und Rohr-
außendurchmesser ergänzen,
TPE 55° Shore

Order codes
for noise protection insert:

EFA-*

complete with clamp size and
outside tube diameter,
TPE 55° Shore

GRÖSSE SIZE SERIE C / SERIES C	Rohr-AD mm O.D. mm	SERIE C / SERIES C		Schalldämmeinlage Noise protection insert
		Schellenkörper für Einlage Tube clamp suitable for insert	Schellenkörper mit Schalldämmeinlage Tube clamp with noise protection insert	
2	10	RCPE-2	RCPEA-210	EFA-410/210
3	10 12 15 18 20	RCPE-3	RCPEA-310 RCPEA-312 RCPEA-315 RCPEA-318 RCPEA-320	EFA-610/310 EFA-612/312 EFA-615/315 EFA-618/318 EFA-620/320
4	22 25 28 30 35	RCPE-4	RCPEA-422 RCPEA-425 RCPEA-428 RCPEA-430 RCPEA-435	EFA-422 EFA-425 EFA-428 EFA-430 EFA-435
5	35 38 42 48,3 60,3	RCPE-5	RCPEA-535 RCPEA-538 RCPEA-542 RCPEA-548,3 RCPEA-560,3	EFA-535 EFA-538 EFA-542 EFA-548,3 EFA-560,3
6	76,1 88,9	RCPE-6	RCPEA-676,1 RCPEA-688,9	EFA-676,1 EFA-688,9
7	114,3	RCPE-7	RCPEA-7114,3	EFA-7114,3

Achtung! Bei Schellen mit Schalldämmeinlage ist die Zuordnung von Durchmesser und Baugröße nicht identisch mit der Profil- bzw. glatten Ausführung.
Attention! For tube clamps with noise protection insert, the relation of diameter and size is not identical with the profile design or smooth design.

DIE VOLLELASTISCHE ROHRSCHELLE

OPTIMALE GERÄUSCH- UND VIBRATIONS DÄMMUNG

THE FULLY FLEXIBLE TUBE CLAMP

OPTIMUM SOUND INSULATION AND VIBRATION DAMPENING

DER GRUNDSTOFF

Die vollelastischen Rohrschellen werden aus thermoplastischem Kautschuk gefertigt.

DIE VORTEILE

Entscheidende Verbesserungen hinsichtlich der Geräuschdämmung und im Vibrationsverhalten. Einfache Befestigung auch empfindlicher Rohr- und Schlauchinstallationen. Die wesentlichen Eigenschaften dieses Materials liegen deutlich über denen vergleichbarer vulkanisierter Gummierzeugnisse.

DIE AUSFÜHRUNGEN

Die Innenflächen sind glatt oder gerippt. Eine sinnvolle Schraubensicherung garantiert auch bei der Vollgummi Ausführung einwandfreie Verbindungen – ein selbstständiges Lösen ist unmöglich! Die Anschweißplatten, Deckplatten und Schrauben sind auch in Edelstahl rostfrei lieferbar.

Lieferbare Abmessungen entnehmen Sie bitte dem Standardprogramm DIN 3015.

THE PRIMARY MATERIAL

The fully flexible tube clamps are made out of thermoplastic caoutchouc.

THE ADVANTAGES

Decisive improvements regarding noise insulation and vibration behaviour. Easy securing also of sensitive tube and pipe installations. The essential qualities of this material are appreciably higher than those of comparable vulcanized rubber products.

THE CONSTRUCTIONS DETAILS

The internal surface are smooth or grooved. A useful screw safety-device guarantees perfect connections also for the solid rubber construction – therefore making a self – acting loosening impossible! The welding plates, covers and screws are also available in stainless steel.

Please order available measurements at the standard range DIN 3015.



Geräusch- und vibrationsarm

Low noise and vibration level

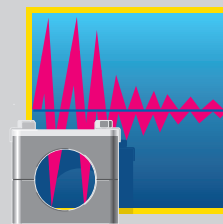

Witterungs- und alterungsbeständig

Weather-proof and brittle-resistant



Formstabilität bei hoher Elastizität

Shape stability with high elasticity



Beständig gegen viele Chemikalien

Resistant against many chemicals



Breiter Temperatur-Einsatzbereich

Wide temperature deployment area

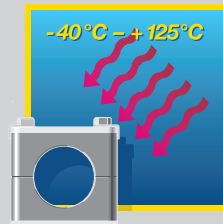

// 02

MULTISCHELLEN

MULTICLAMPS

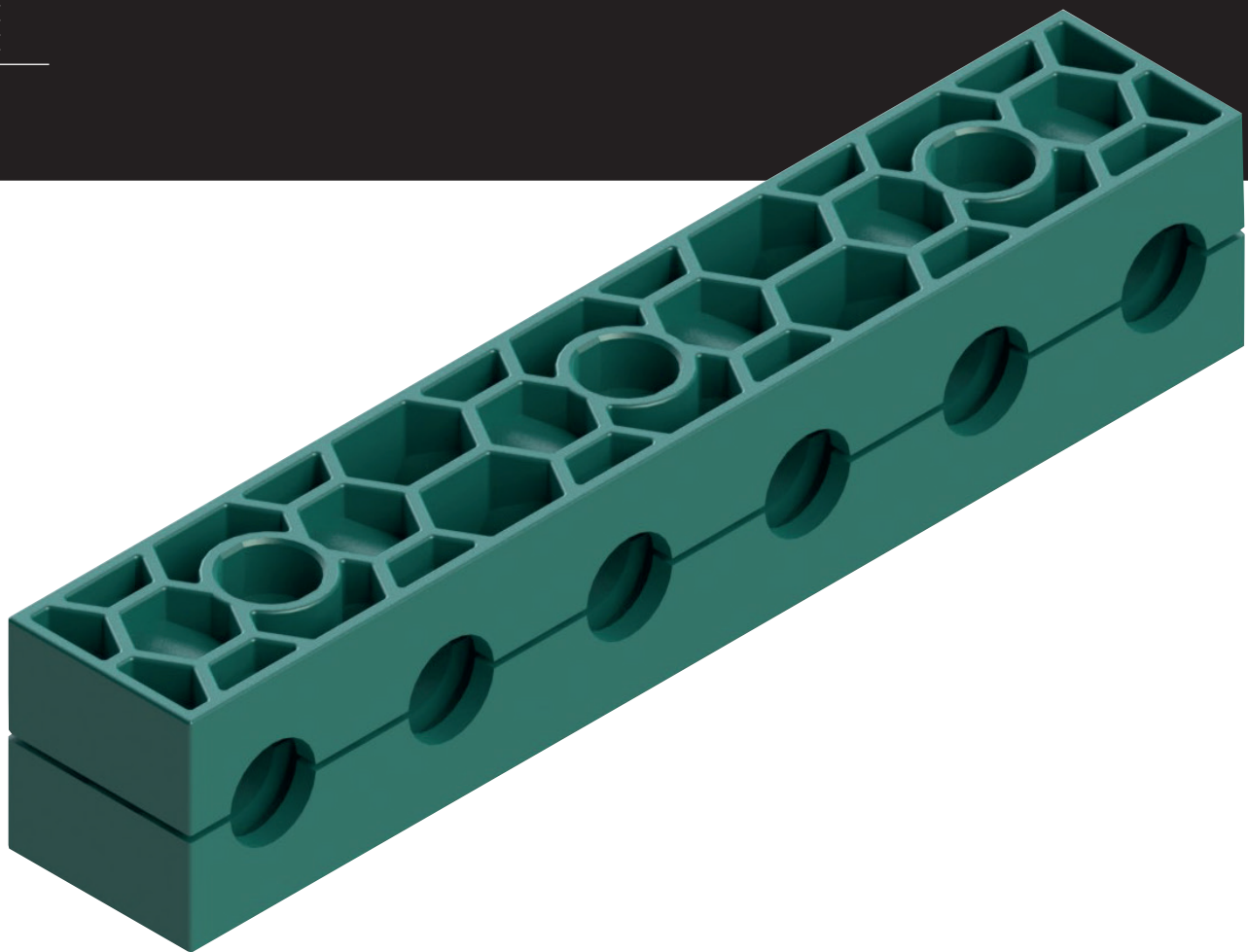

Bestellzeichen für Schellenhälften:

Polypropylen **RAPRM**
innen glatt **RAPGM²⁾**
Polyamid 6 **RANRM**
innen glatt **RANGM²⁾**
Vollgummi **RAVGM^{2) 3)}**

Bei Bedarf Standardkurzzeichen RAPRM in der Spalte „Schellenhälften“ austauschen.

Order codes for clamp-halves:

Polypropylene **RAPRM**
inside smooth **RAPGM²⁾**
Polyamide 6 **RANRM**
inside smooth **RANGM²⁾**
Rubber **RAVGM^{2) 3)}**

Replace standard abbreviation RAPRM in column "clamp-halves" as required.

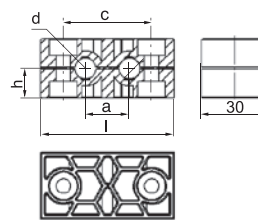

GRÖSSE SIZE	Rohr-AD mm O.D. mm d ₁	Anzahl der Rohre Number of tubes	RAPRM	RAPRM-...				Befestigungsschrauben Fastening screws B
			1 Stück / 2 Schellenhälften 1 part / 2 clamp-halves	a	c	h	l	
1	6 6,4 8 9,5 10 12	2	RAPRM-1xxxB2	20	40	13,5	60,5	2
2	10 12 12,7 13,5 14 15 16 17,2 18	2	RAPRM-2xxxB2	29	58	16,5	78,5	2
3	15 16 17,2 18 19 20 21,3 22 23 25 25,4	2	RAPRM-3xxxB2	36	72	18,5	92,5	2

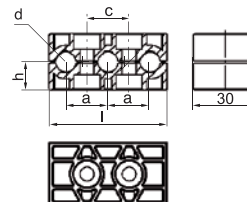
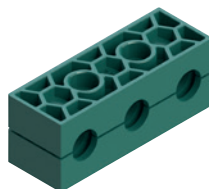

GRÖSSE SIZE	Rohr-AD mm O.D. mm d ₁	Anzahl der Rohre Number of tubes	RAPRM	RAPRM-...				Befestigungsschrauben Fastening screws B
			1 Stück / 2 Schellenhälften 1 part / 2 clamp-halves	a	c	h	l	
1	6 6,4 8 9,5 10 12	3	RAPRM-1xxxB3	20	20	13,5	56	2
2	10 12 12,7 13,5 14 15 16 17,2 18	3	RAPRM-2xxxB3	29	29	16,5	85	2
3	15 16 17,2 18 19 20 21,3 22 23 25 25,4	3	RAPRM-3xxxB3	36	36	18,5	106	2

²⁾ohne Vorspannung

³⁾Bei Montage von Vollgummi-Schellen sind Deckplatten, Sechskantschrauben und Sicherungsscheiben zu verwenden

²⁾without prestress

³⁾When assembling solid rubber tube clamps, cover plates, hexagon head screws and locking washers must be used

MULTISCHELLE SERIE A | EINZELTEILE
MULTICLAMP SERIES A | COMPONENTS

Bestellzeichen für Schellenhälften:

Polypropylen
 innen glatt
 Polyamid 6
 innen glatt
 Vollgummi

RAPRM
RAPGM²⁾
RANRM
RANGM²⁾
RAVGM^{2) 3)}

Order codes for clamp-halves:

Polypropylene
 inside smooth
 Polyamide 6
 inside smooth
 Rubber

RAPRM
RAPGM²⁾
RANRM
RANGM²⁾
RAVGM^{2) 3)}

Bei Bedarf Standardkurzzeichen RAPRM in der Spalte „Schellenhälften“ austauschen.

Replace standard abbreviation RAPRM in column "clamp-halves" as required.

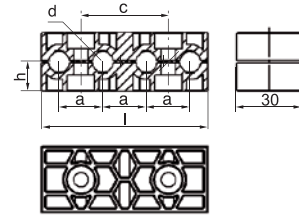
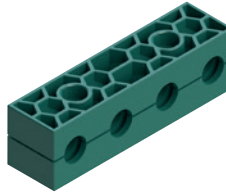

GRÖSSE SIZE	Rohr-AD mm O.D. mm	Anzahl der Rohre Number of tubes	RAPRM	RAPRM-...				Befestigungsschrauben Fastening screws
	d ₁		1 Stück / 2 Schellenhälften 1 part / 2 clamp-halves	a	c	h	l	
1	6	4	RAPRM-1xxxB4	20	40	13,5	76	2
	6,4							
	8							
	9,5							
	10							
12								
2	10	4	RAPRM-2xxxB4	29	58	16,5	114	2
	12							
	12,7							
	13,5							
	14							
	15							
	16							
	17,2							
18								
3	15	4	RAPRM-3xxxB4	36	72	18,5	142	2
	16							
	17,2							
	18							
	19							
	20							
	21,3							
	22							
	23							
	25							
	25,4							

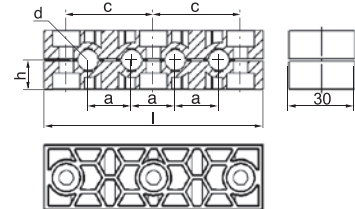
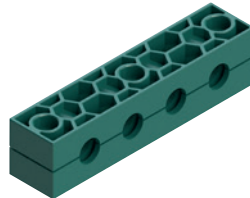

GRÖSSE SIZE	Rohr-AD mm O.D. mm	Anzahl der Rohre Number of tubes	RAPRM	RAPRM-...				Befestigungsschrauben Fastening screws
	d ₁		1 Stück / 2 Schellenhälften 1 part / 2 clamp-halves	a	c	h	l	
1	6	4	RAPRM-1xxxC4	20	40	13,5	100,5	3
	6,4							
	8							
	9,5							
	10							
12								
2	10	4	RAPRM-2xxxC4	29	58	16,5	136,5	3
	12							
	12,7							
	13,5							
	14							
	15							
	16							
	17,2							
18								
3	15	4	RAPRM-3xxxC4	36	72	18,5	164,5	3
	16							
	17,2							
	18							
	19							
	20							
	21,3							
	22							
	23							
	25							
	25,4							

²⁾ohne Vorspannung

³⁾Bei Montage von Vollgummi-Schellen sind Deckplatten, Sechskantschrauben und Sicherungsscheiben zu verwenden

²⁾without prestress

³⁾When assembling solid rubber tube clamps, cover plates, hexagon head screws and locking washers must be used

Bestellzeichen für Schellenhälften:

Polypropylen **RAPRM**
 innen glatt **RAPGM²⁾**
 Polyamid 6 **RANRM**
 innen glatt **RANGM²⁾**
 Vollgummi **RAVGM^{2) 3)}**

Bei Bedarf Standardkurzzeichen RAPRM in der Spalte „Schellenhälften“ austauschen.

Order codes for clamp-halves:

Polypropylene **RAPRM**
 inside smooth **RAPGM²⁾**
 Polyamide 6 **RANRM**
 inside smooth **RANGM²⁾**
 Rubber **RAVGM^{2) 3)}**

Replace standard abbreviation RAPRM in column "clamp-halves" as required.

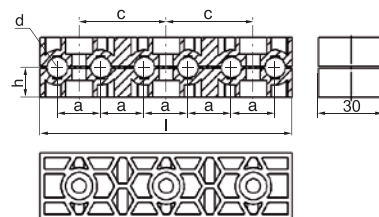
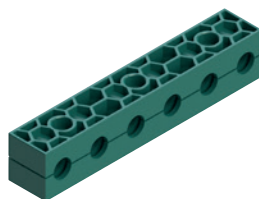

GRÖSSE SIZE	Rohr-AD mm O.D. mm	Anzahl der Rohre Number of tubes	RAPRM 1 Stück / 2 Schellenhälften 1 part / 2 clamp-halves	RAPRM-...				Befestigungsschrauben Fastening screws C
	d ₁			a	c	h	l	
1	6	6	RAPRM-1xxxC6	20	40	13,5	116	3
	6,4							
	8							
	9,5							
	10							
2	12	6	RAPRM-2xxxC6	29	58	16,5	172	3
	12,7							
	13,5							
	14							
	15							
	16							
	17,2							
3	18	6	RAPRM-3xxxC6	36	72	18,5	214	3
	15							
	16							
	17,2							
	18							
	19							
	20							
	21,3							
	22							
	23							
25								
25,4								

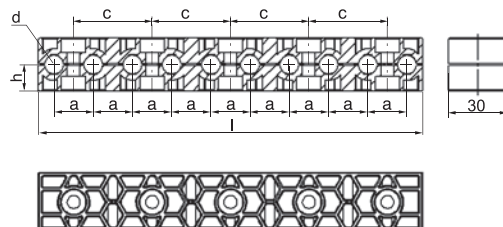
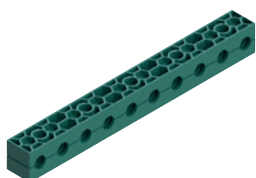

GRÖSSE SIZE	Rohr-AD mm O.D. mm	Anzahl der Rohre Number of tubes	RAPRM 1 Stück / 2 Schellenhälften 1 part / 2 clamp-halves	RAPRM-...				Befestigungsschrauben Fastening screws E
	d ₁			a	c	h	l	
1	6	10	RAPRM-1xxxE10	20	40	13,5	196	5
	6,4							
	8							
	9,5							
	10							
2	12	10	RAPRM-2xxxE10	29	58	16,5	288	5
	12,7							
	13,5							
	14							
	15							
	16							
	17,2							
3	18	10	RAPRM-3xxxE10	36	72	18,5	358	5
	15							
	16							
	17,2							
	18							
	19							
	20							
	21,3							
	22							
	23							
25								
25,4								

²⁾ohne Vorspannung

³⁾Bei Montage von Vollgummi-Schellen sind Deckplatten, Sechskantschrauben und Sicherungsscheiben zu verwenden

²⁾without prestress

³⁾When assembling solid rubber tube clamps, cover plates, hexagon head screws and locking washers must be used

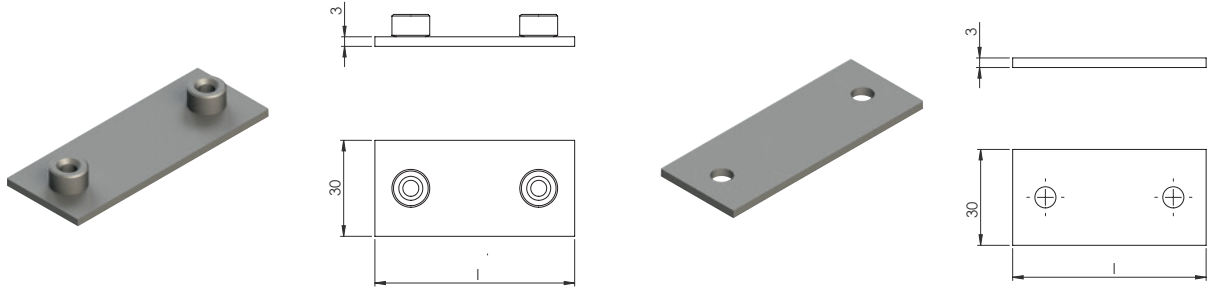

GRÖSSE SIZE	APM-A Anschweißplatte Weld plate						DPM-A Deckplatte Cover plate					
	B2	B3	B4	C4	C6	E10	B2	B3	B4	C4	C6	E10
1	62,5	58	78	102,5	118	198	60,5	56	76	100,5	116	196
2	80,5	87	116	138,5	174	290	78,5	85	114	136,5	172	288
3	94,5	108	144	166,5	216	360	92,5	106	142	164,5	214	358

// BESTELLBEISPIEL

RAPRM-1xx/B2
RAPRM-106/8/B2
RAPRM-315/21,3/25,4/B3

R A P R M - 1 06 / B 4

R	A	P	R	M	-	1	06	/	B	4
										Anzahl der Rohre
										Anzahl der Schrauben A = 1, B = 2, C = 3, D = 4, E = 5
										Durchmesser
										Schellengröße
										Variante M = Multi
										Innenfläche R = Rippen, G = Glatt
										Werkstoff P = Polypropylen, N = Polyamid, V = TPE
										Serie A = Leichtbaureihe
Rohrschelle / Schellenkörper										

// EXAMPLE OF ORDER

RAPRM-1xx/B2
RAPRM-106/8/B2
RAPRM-315/21,3/25,4/B3

R A P R M - 1 06 / B 4

R	A	P	R	M	-	1	06	/	B	4
										Number of Tubes
										Number of screws A = 1, B = 2, C = 3, D = 4, E = 5
										Diameter
										Clamp size
										Version M = Multi
										Interior surface R = grooved, G = smooth
										Material P = polypropylene, N = polyamide, V = TPE
										Serie A = Light construction series
Tube clamp										

Metallteile in Edelstahl lieferbar.
All metal parts are available in stainless steel.



// 06

ROHRSCHELLEN SERIE O

TUBE CLAMPS SERIES O



- schnelle Montage
- geringer Platzbedarf
- Deckplatte sorgt für stabile Befestigung
- sichere Klemmung der Rohre durch Vorspannung
- verschiedene Rohrdurchmesser kombinierbar
- Befestigung mit Schrauben
- besonders geeignet für Kabel, Schläuche, Gas-, Öl- und Schmierleitungen
- Metallteile auch in Edelstahl lieferbar

- quick assembly
- space-saving
- Cover plate provides for stable fixing
- secure clamping of tubes due to pre-clamping
- different tube diameters combinable
- Fixing with screws
- particularly suitable for cables, hoses, gas and oil pipes, lubricating lines
- Metal parts also available in stainless steel



Rohrschelle Serie O
platzsparend und flexibel
von Ø 6 mm bis 22 mm

Tube clamp series O
space-saving and flexible
from Ø 6 mm to 22 mm

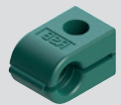

Doppel-Rohrschelle
Serie O mit gleichen
Durchmessern
von Ø 6 mm bis 22 mm

Double-tube clamp series O
with same diameters
from Ø 6 mm to 22 mm

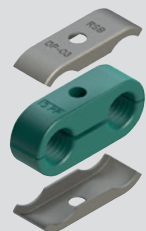

Doppel-Rohrschelle Serie O
mit unterschiedlichen
Durchmessern von
Ø 6 mm bis 22 mm

Double-tube clamp series
O with different diameters
from Ø 6 mm to 22 mm

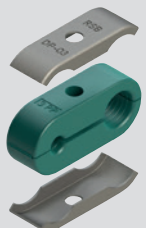

// ROHRSCHELLE SERIE O

// TUBE CLAMP SERIES O

Bestellzeichen für Schellenhälften:

Polypropylen **ROP-***
Polyamid **RON-***

* ergänzen mit Größe und Durchmesser (z.B. ROP-106)

Verpackungseinheiten:
100 Stück

Order codes for clamp-halves:

Polypropylene **ROP-***
Polyamide **RON-***

* supplement with size and tube Ø mm (e.g. ROP-106)

Packing standard:
100 pieces

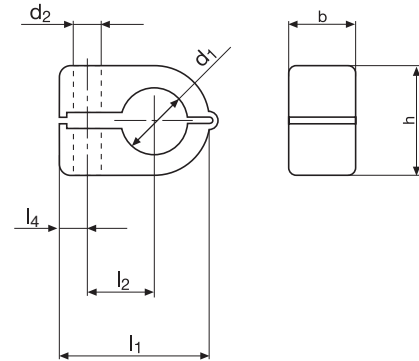

ANWENDUNGSBEREICHE

NOISE PROTECTION INSERT

Anwendungsbereiche:

- Drucklufttechnik
- Fahrzeugbau
- Maschinenbau
- Mess- und Regeltechnik
- Schiffsbau
- geeignet für Kabel und Schläuche

Areas of application:

- Pneumatics
- Automotive Technology
- Machine tool industry
- Lubrication
- Naval Technology
- suitable for cables and hoses

GRÖSSE SIZE	Rohr-Ø d ₁ / Tube Ø d ₁			l ₁	l ₂	l ₄	b	h	d ₂
	mm O.D. mm	Rohrzoll Tube NB	Inch Inch						
1	6		1/4	23	9			13,5	
	6,4								
	8								
2	8	G 1/8	3/8	27	11	7		18,5	
	9,5								
	10								
	12								
3	12,7	G 1/4	1/2	34	15		14,5	23,5	6,5
	14								
	15								
	16								
	16								
4	14	G 3/8	5/8	40	19	6		30,5	
	15								
	16								
	17,2								
	18								
	19								
	20								
21,3	G 1/2	3/4							
22									

// DOPPEL-ROHRSCHELLE SERIE O // DOUBLE-TUBE CLAMP SERIES O

Bestellzeichen für Schellenhälften:

Polypropylen **ROPD-***
Polyamid **ROND-***

* ergänzen mit Größe und Durchmesser (z.B. ROPD-106), unterschiedliche Durchmesser auf Anfrage

Verpackungseinheiten:
100 Stück

Order codes for clamp-halves:

Polypropylene **ROPD-***
Polyamide **ROND-***

* supplement with size and tube Ø mm (e.g. ROPD-106), different diameters on request

Packing standard:
100 pieces

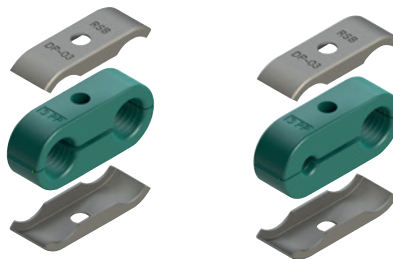

DECKPLATTE COVER PLATE

Bestellzeichen: DP-O*

* ergänzen mit Größe

Material: Stahl verzinkt
(Edelstahl auf Anfrage)

Order codes: DP-O*

* supplement with size

Material: Galvanized steel
(Stainless steel upon request)

ANWENDUNGSBEREICHE NOISE PROTECTION INSERT

Anwendungsbereiche:

- Drucklufttechnik
- Fahrzeugbau
- Maschinenbau
- Mess- und Regeltechnik
- Schiffsbau
- geeignet für Kabel und Schläuche

Areas of application:

- Pneumatics
- Automotive Technology
- Machine tool industry
- Lubrication
- Naval Technology
- suitable for cables and hoses

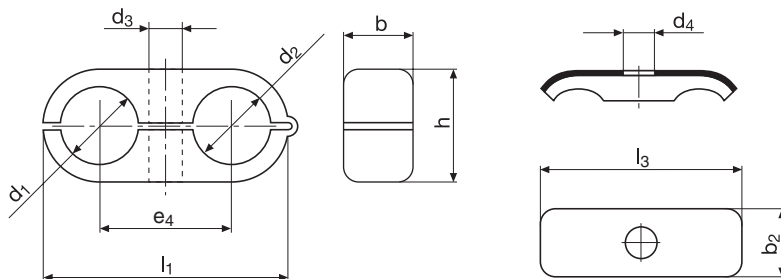

GRÖSSE SIZE	Rohr-Ø d1+ d2 / Tube Ø d1+ d2			l ₁	e ₄	b	h	d ₃	l ₃	b ₂	d ₄	
	mm O.D. mm	Rohrzoll Tube NB	Inch Inch									
1	6		1/4	32	18		13,5		29			
	6,4											
	8											
2	8	G 1/8	3/8	41	22		18,5		40	16,3		
	9,5											
	10											
	12,7											1/2
3	10	G 1/4	1/2	54	30	14,5	23,5	6,5	50,5		6,5	
	12											
	12,7											
	14											
	15											
4	16	G 3/8	5/8	69	38		30,5		63	16,5		
	14											
	15											
	16											
	17,2											
	18											3/4
	19											
20												
21,3	G 1/2											
22												

Metallteile in Edelstahl lieferbar.
All metal parts available in stainless steel.



// 06

ROHRBEFESTIGUNG AUF EINEM ZYLINDER

Rohrlager - Adapter - Klammer - Spannband

TUBE FASTENING ON A CYLINDER

Tube support - Adaptor - Clip - Worm thread clamps

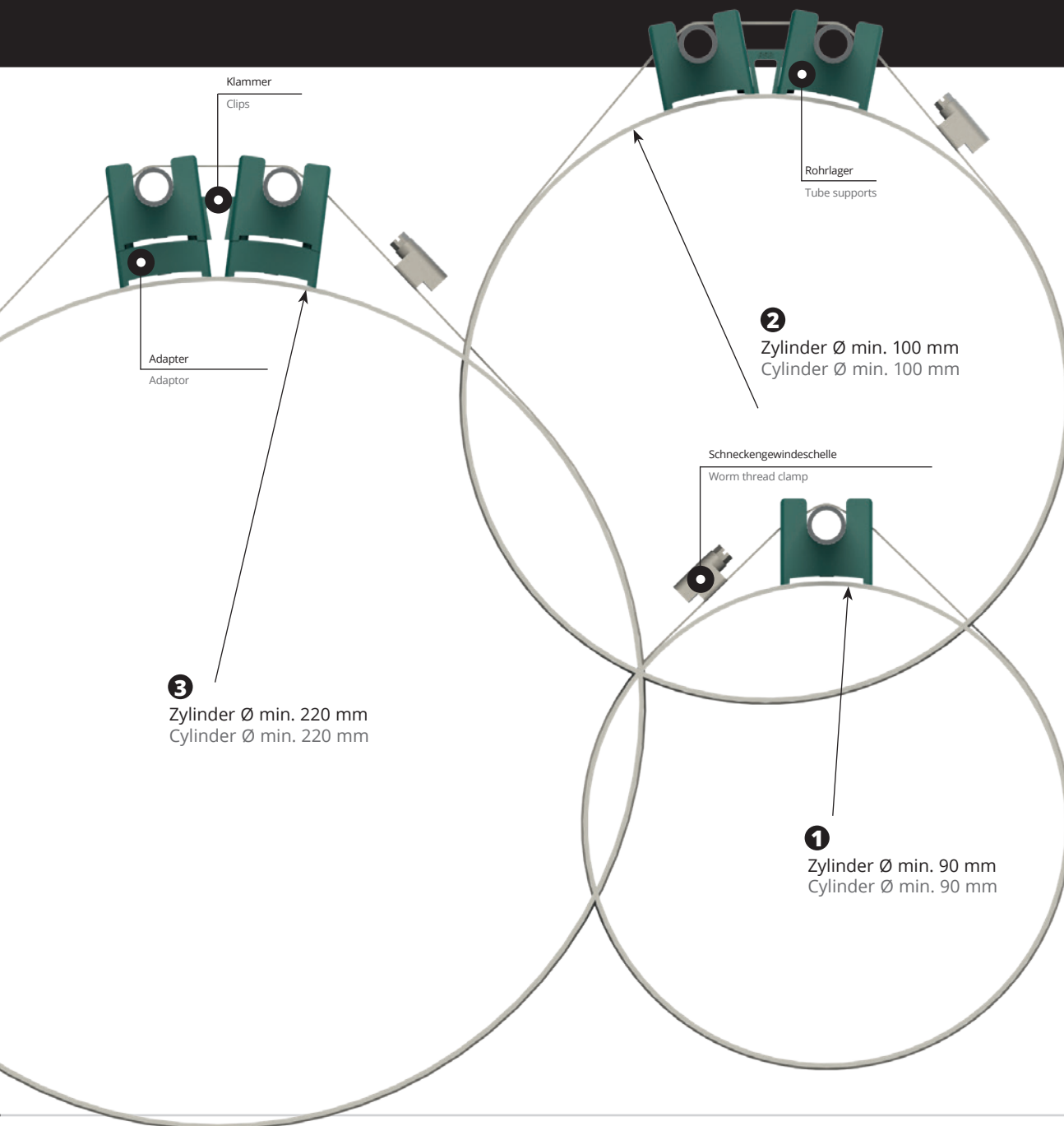

DIE MONTAGE: DAS „CLIP + FERTIG“-PRINZIP! ASSEMBLY: THE “CLIP + READY”-SYSTEM!

1.

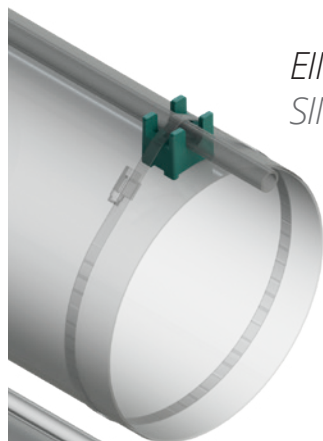

EINZELMONTAGE
 SINGLE ASSEMBLY

Rohrlager ohne Adapter
 Tube support without adaptor

2.

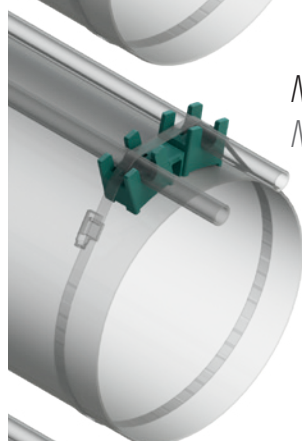

MEHRFACH-MONTAGE
 MULTIPLE ASSEMBLY

Rohrlager mit Klammer
 Tube support with clip

3.

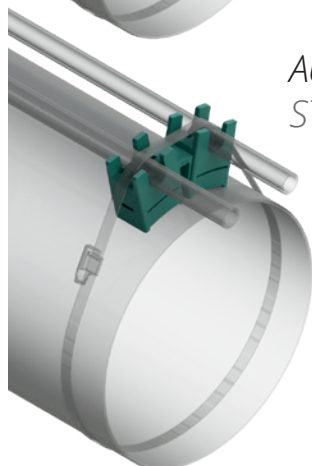

AUFBAU-MONTAGE
 STACKING ASSEMBLY

Rohrlager mit Adapter
 Tube support with adaptor

ROHRLAGER, ADAPTER, KLAMMER UND SPANNBAND SIND ALS SYSTEM AUSGELEGT.

Als Einzelteil oder in Kombination lassen sich praxisbezogen unterschiedliche Montagesituationen realisieren.

Berücksichtigt werden hierbei:

- Montage von Rohren oder Schläuchen auf Hydraulik-Zylindern
- unterschiedliche Rohr- oder Schlauch-Durchmesser
- unterschiedliche Rohrabstände zum Zylinder
- die Montage mehrerer Rohrlager für unterschiedliche Rohrdurchmesser

THE COMPLETE SYSTEM CONSISTS OF THE FOLLOWING INDIVIDUAL COMPONENTS:

Tube support, adaptor, clip and worm thread clamps. Practical solutions for many different assembly situations can be found by either using an individual component or by combining all the components.

For example:

- Assembly of tubes or hoses on hydraulic cylinder
- different tube or hose diameters
- different distances between tubes and cylinder
- the assembly of several tube supports for different tube diameters

	BILD / FIGURE 1.	BILD / FIGURE 2.	BILD / FIGURE 3.
Montage auf Hydr.-Zylinder Assembly hydr. cylinder	Einzelmontage Rohrlager ohne Adapter Single-part assembly Tube support without adaptor	Montage mehrerer Rohrlager mit Klammer ohne Adapter Assembly several tube supports with clip without adaptor	Montage mehrerer Rohrlager für verschiedene Rohr-Ø mit Klammer und Adapter Assembly several tube supports with clip adaptors
Zylinder / Cylinder Ø	min. Ø 90 mm	min. Ø 100 mm	min. Ø 220 mm

// ROHRLAGER // TUBE SUPPORT

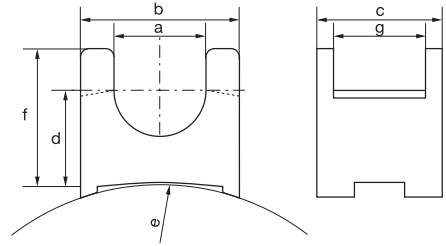
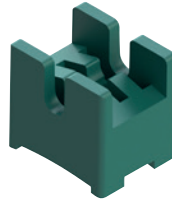

Bestellzeichen:

Polypropylen **RLP**

Mit dem Rohrlager RLP werden Rohre oder Schläuche unter Verwendung einer Schnecken-gewindeschelle (Spannband) auf Hydraulik-Zylinder montiert.

Siehe Bild 1

Order codes:

Polypropylene **RLP**

With the RLP tube support, tubes or hoses can be fitted on hydraulic cylinders by using a worm thread clamp.

See figure 1

GRÖSSE SIZE Rohr-Ø / Tube Ø mm	Bestellzeichen Order Codes	a	b	c	d	e	f	g
8	RLP-8	8						
10	RLP-10	10						
12	RLP-12	12						
15	RLP-15	15						
16	RLP-16	16	38	30	21	R 110	32	22
18	RLP-18	18						
20	RLP-20	20						
22	RLP-22	22						
25	RLP-25	25						

// ADAPTER // ADAPTOR

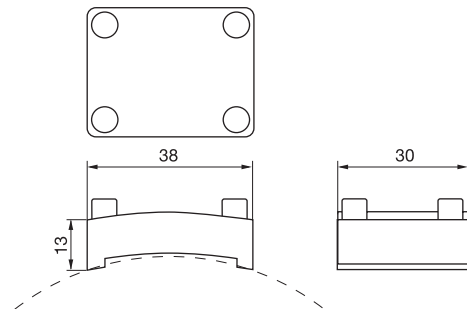
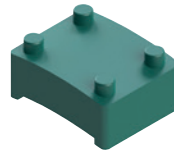

Bestellzeichen:

Polypropylen **ADP**

Der Adapter ADP wird unter das Rohrlager geklippt, um größere Rohrabstände zum Zylinder zu erzielen.

Siehe Bild 3

Order codes:

Polypropylene **ADP**

The ADP adaptor is clipped beneath the tube support in order to get a bigger distance between the tube and the cylinder.

See figure 3

// KLAMMER // CLIPS

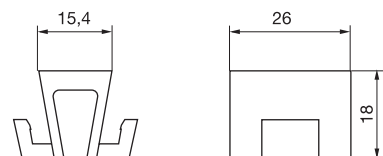
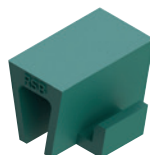

Bestellzeichen:

Polypropylen **KLP**

Mit der Klammer KLP können Rohrlager zusammen-gefasst werden, um eine Montage von mehreren Rohren oder Schläuchen zu erleichtern.

Siehe Bild 2 und 3

Order codes:

Polypropylene **KLP**

KLP clips allow the assembly of tube supports. The tube supports are clipped together with the clip.

See figures 2 and 3

// SCHNECKENGEWINDESCHELLEN // WORM THREAD CLAMPS

Bestellzeichen: **SGS**

* Bestellzeichen ergänzen:
W1: Stahl verzinkt
W5: Rostfreier Stahl

**Abmessungen nur für eine Rohrleitung auf Rohrlager!

Bei Montage von mehr als einer Rohrleitung auf den Zylinder oder/und Aufbau mit Adapter sind entsprechend größere Schellen zu verwenden!

Order codes: **SGS**

* please add. to order code:
W1: Steel zinc plated
W5: Stainless steel

**Dimensions to use 1 pipe on 1 support!

Use clamps of the correct size when assembling more than one tube on the cylinder or/and when using the adaptor!

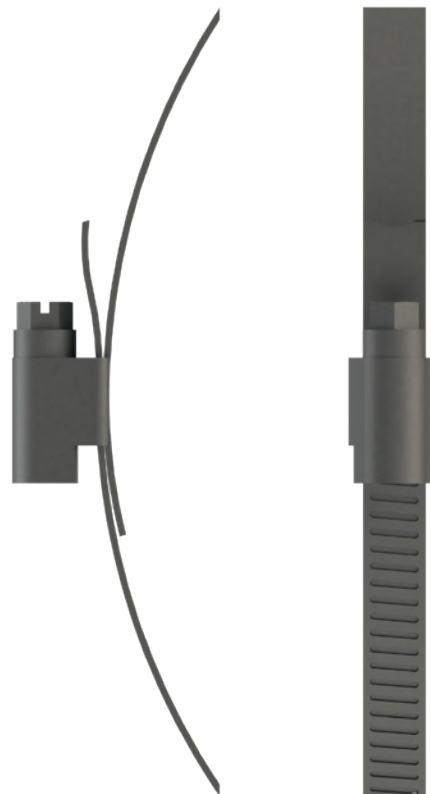

SCHNECKENGEWINDESCHELLEN NACH DIN 3017 / WORM THREAD CLAMPS DIN 3017

Bandbreite Strip width	Bestellzeichen Order Codes	Passend für Zylinder-Ø** Fits cylinders**
12	SGS-100-120/W*	90 – 110
	SGS-110-130/W*	100 – 120
	SGS-120-140/W*	110 – 130
	SGS-130-150/W*	120 – 140
	SGS-140-160/W*	130 – 150
	SGS-150-170/W*	140 – 160
	SGS-160-180/W*	150 – 170
	SGS-170-190/W*	160 – 180
	SGS-180-200/W*	170 – 190
	SGS-190-210/W*	180 – 200
	SGS-200-220/W*	190 – 210
	SGS-210-230/W*	200 – 220
	SGS-220-240/W*	210 – 230
	SGS-230-250/W*	220 – 240
	SGS-240-260/W*	230 – 250
SGS-250-270/W*	240 – 260	
SGS-260-280/W*	250 – 270	



// 07

Sicher und vibrationshämmend

HYDRAULIK-STAHLSCHELLE

Save and vibration-insulation

HYDRAULIC STEEL CLAMP

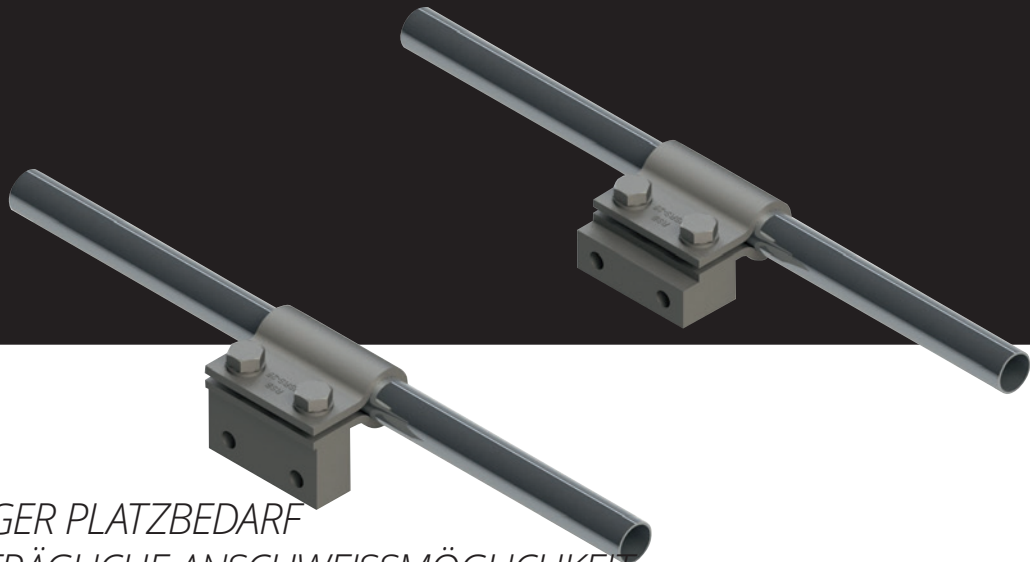

*GERINGER PLATZBEDARF
NACHTRÄGLICHE ANSCHWEISSMÖGLICHKEIT
SCHWINGUNGSFREIES VERLEGEN VON ROHREN*

*SPACE-SAVING SYSTEM
CAN BE WELDED AFTERWARDS
ALLOWS VIBRATION-FREE LAYING AND MOUNTING OF TUBES*

KONSTRUKTION

Obere und untere Schellenhälfte sind identisch. Das Halteteil wird flach oder hochkant angeschweißt.

ANWENDUNGSBEREICHE

Die Schelle ist in der gesamten Mobil-Hydraulik, auch für den nachträglichen Einbau, einsetzbar.

DESIGN

Top and bottom clamp halves are identical. The support-block is welded in upend or flat position.

FIELD OF APPLICATION

The clamp is used for the whole mobile hydraulic. The small dimension of the clamp allows hydraulic tubes and hoses to be mounted afterwards.

MACHEN SIE IHRE BAUMASCHINEN FIT MIT HSRs

HYDRAULIK-ROHRSCHELLE HSRs

DO UP YOUR CONSTRUCTION MACHINES WITH HSRs

HYDRAULIC STEEL CLAMP HSRs

NACHTRÄGLICHE ANSCHWEISSMÖGLICHKEIT SCHWINGUNGSFREIES VERLEGEN VON ROHREN

WELD-ON POSSIBILITY LATER ON VIBRATION-FREE INSTALLATION OF TUBES AND HOSES

Die robuste Bauart der Schelle wirkt schlag- und vibrationsdämmend. Ein nachträgliches Verlegen von Hydraulikleitungen – zum Beispiel für den Anbau von Zusatzgeräten an Baumaschinen – ist durch die geringe Höhe der Schelle jederzeit möglich.

Die Schalldämmeinlage sorgt für eine verbesserte Geräuschkämmung und garantiert eine sichere Befestigung empfindlicher Rohr- und Schlauchleitungen.

The robust construction of the clamp provides for impact and vibration reduction. The low height of this clamp type allows hydraulic lines to be installed at any time later on – e.g. for the installation of additional units on construction machines.

The noise protection inlay provides for an improved noise reduction and guarantees the safe fastening of sensitive tubes and host lines.



// HYDRAULIK-STAHLSCHELLE

// HYDRAULIC STEEL CLAMP

Bestellzeichen:

W1: Stahl verzinkt **HSRS-***

* Bestellzeichen ergänzen mit $\varnothing d_2$

Hydraulik-Stahlschellen HSRS finden vorwiegend im Bereich Baumaschinen Verwendung.

Das Halteteil wird hochkant oder flach aufliegend an den Maschinenkörper oder ein anderes Bauteil geschweißt. Die Rohrschelle wird angeschraubt.

Die robuste Bauart der Schelle wirkt schlag- und vibrationsdämmend. Ein nachträgliches Verlegen von Hydraulikleitungen – zum Beispiel für den Anbau von Zusatzgeräten an Baumaschinen – ist durch die geringe Höhe der Schelle jederzeit möglich.

Order codes:

W1: Steel zinc plated **HSRS-***

* please add. $\varnothing d_2$

HSRS hydraulic steel clamps are mainly used in the field of construction machinery.

The support-block is welded to the machine body or another component either in upend or flat position.

The robust construction of the clamp has an impact- and vibration-insulation effect. The small dimension/height of the clamp allows hydraulic cables to be fitted on later – e.g. for installing additional equipment to building machinery.

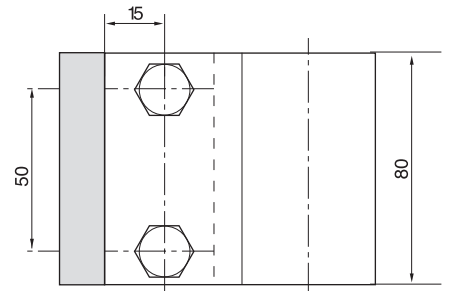
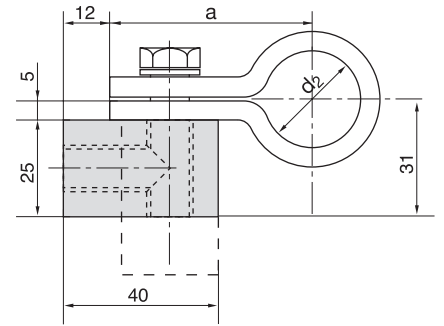

Bestellzeichen Order codes	Maße / Measurement	
	$\varnothing d_2$	a
HSRS-25	25	52,5
HSRS-30	30	55
HSRS-35	35	57,5
HSRS-38	38	59
HSRS-42	42	61
HSRS-48	48	64
HSRS-50	50	65
HSRS-60 ¹⁾	60	70

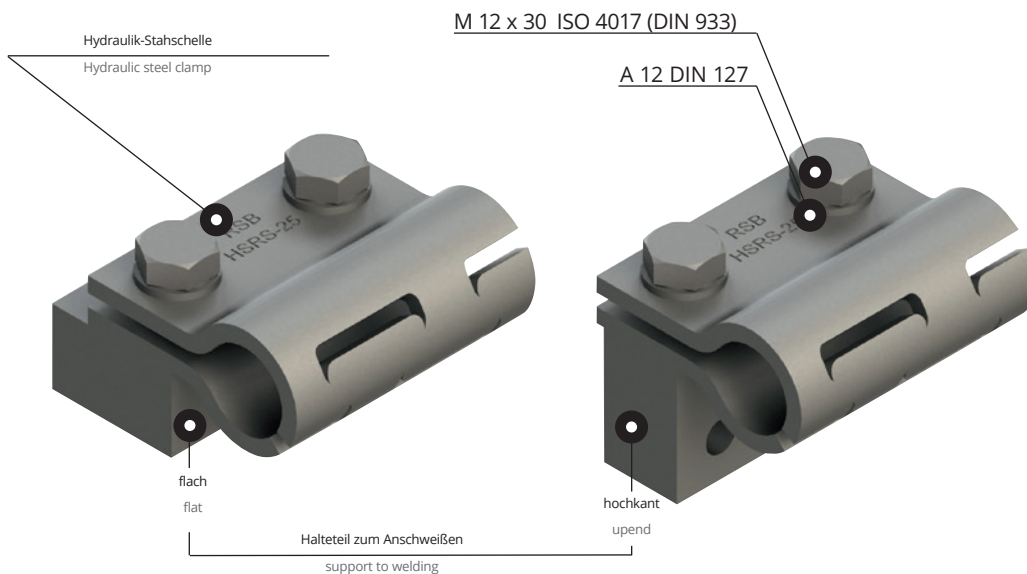

¹⁾ Halteteil nur hochkant einsetzbar

¹⁾ The support can only be used in upright position

SCHALLDÄMMEINLAGE
NOISE PROTECTION INSERT

Bestellzeichen: EE-*

* Bestellzeichen ergänzen mit Nenngröße der Schelle und Rohraußendurchmesser

Hydraulik-Stahlschelle HSRS wahlweise auch mit Schalldämmeinlage.

Vorteil:

- verbesserte Geräusch- und Vibrationsdämmung
- sichere Befestigung auch empfindlicher Rohr und Schlauchleitungen
- mehrere Rohrdurchmesser mit einer Schelle möglich

Werkstoff:

- TPE 64° Shore
- hohe Öl- und Witterungsbeständigkeit,
 - Temperaturbeständigkeit von -40 bis +120°C

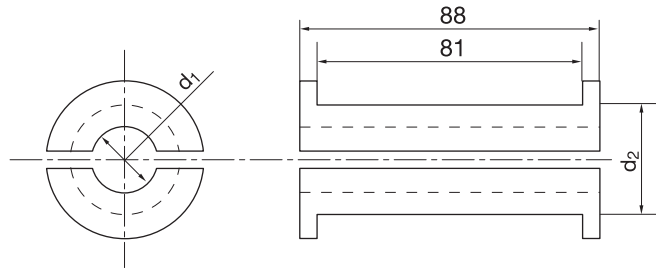

Order codes: EE-*

* complete with nominal clamp size and outside tube diameter

Hydraulic steel clamp HSRS also available with noise protection insert.

The advantages:

- improved quality as regards noise and vibration reduction
- safe fastening method even for very sensitive tube and hose lines
- only one clamp for different tube diameters

Material:

- TPE 64° Shore
- high oil and weathering resistance
 - Temperature stability between -40°C and +120°C

Bestellzeichen Order codes	Schelle Nenngröße Nominal size Ø d ₂	Rohr-Ø mm Tube Ø mm d ₁
EE 25-12	HSRS-25	12
EE 25-15		15
EE 30-20	HSRS-30	20
EE 35-25	HSRS-35	25
EE 42-30	HSRS-42	30
EE 50-35	HSRS-50	35
EE 50-38		38
EE 50-42		42
EE 60-47	HSRS-60	47
EE 60-50		50





VISITEC

SCHLAUCHFÜHRUNG

HOSE GUIDE



Bestellzeichen:
 Polypropylen **SHP**

Order codes:
 Polypropylene **SHP**

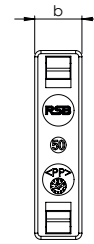
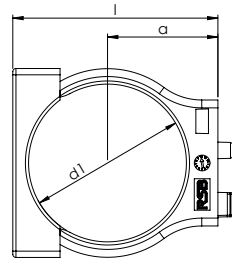

Bestellzeichen Order Codes	SHP Maße Measurements			
	d ₁	a	l	b
SHP-14	14	17	35,6	15
SHP-16	16	18	36,9	
SHP-17	17	18,5	37,5	
SHP-18	18	19	38,1	
SHP-20	20	20	40,3	
SHP-21,5	21,5	20,8	41,6	
SHP-24	24	22	43,6	
SHP-26	26	23	45,3	
SHP-28,5	28,5	24,3	46	
SHP-30	30	25	48,3	
SHP-35	35	27,5	54,7	
SHP-43	43	31,5	60,3	
SHP-50	50	35	65	
SHP-65	65	42,5	79,8	

// BESTELLBEISPIEL

SH | P | - | 35 | Visitec

Durchmesser /
Anzahl Verbindungsstellen

Werkstoff
P=Polypropylen

SH=Schlauchführung (mit Sicherungsbügel)
 ASH=Anschraubverbinder für Schlauchführung
 VSH=Verbinder für Schlauchführungen

// EXAMPLE OF ORDER

SH | P | - | 35 | Visitec

Diameter /
Number of junctions

Material
P=polypropylene

SH=Hose guide (with safety bracket)
 ASH=Screw connector for hose guide
 VSH=Connector for hose guides

// 3ER-VERBINDER FÜR SCHLAUCHFÜHRUNGEN // 3-WAY CONNECTOR FOR HOSE GUIDES

Bestellzeichen:
Polypropylen **VSHP-3**

Order codes:
Polypropylene **VSHP-3**

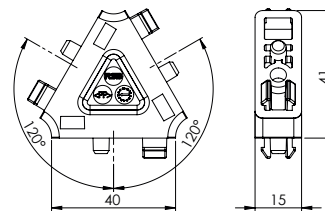

// 4ER-VERBINDER FÜR SCHLAUCHFÜHRUNGEN // 4-WAY CONNECTOR FOR HOSE GUIDES

Bestellzeichen:
Polypropylen **VSHP-4**

Order codes:
Polypropylene **VSHP-4**

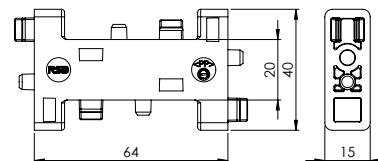

// ANSCHRAUBVERBINDER FÜR SCHLAUCHFÜHRUNGEN // SREW CONNECTOR FOR HOSE GUIDES

Bestellzeichen:
Polypropylen **ASHP-1**

Order codes:
Polypropylene **ASHP-1**

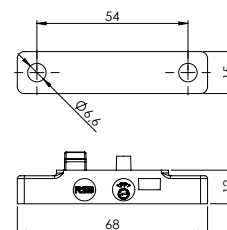

ÜBERZEUGENDE VORTEILE
CONVINCING ADVANTAGES

- Einfache Montage ohne Beschädigung der Schläuche
- Flexible Installation
- Variable Durchmesser
- Fixation von bis zu vier Schläuchen unterschiedlicher Durchmesser
- Erhaltung der vollen Flexibilität
- Erfolgreiche Erprobung in der Praxis

Die besondere Fertigung und das neue Design ermöglichen eine flexible Installation der Schläuche; gleichzeitig werden Beschädigungen während der Montage verhindert.

Durch die variable Anzahl der Durchmesser sind Führungen von bis zu vier Schläuchen möglich. Die neue VISITEC Schlauchführung von RSB steht für eine schnelle und einfache Montage mit vielfältigen Installationsmöglichkeiten.

- Simple assembly without damaging the hoses
- Flexible installation
- Variable diameters
- Fixation of up to four hoses with different diameters
- Maintaining complete flexibility
- Successful field testing

The special manufacture and the new design allow for a flexible installation of the hoses; at the same time, damage during assembly is prevented. Due to the variable number of diameters, guides of up to four hoses are possible. The new VISITEC hose guide from RSB features can be assembled quickly and easily with many different installation options.

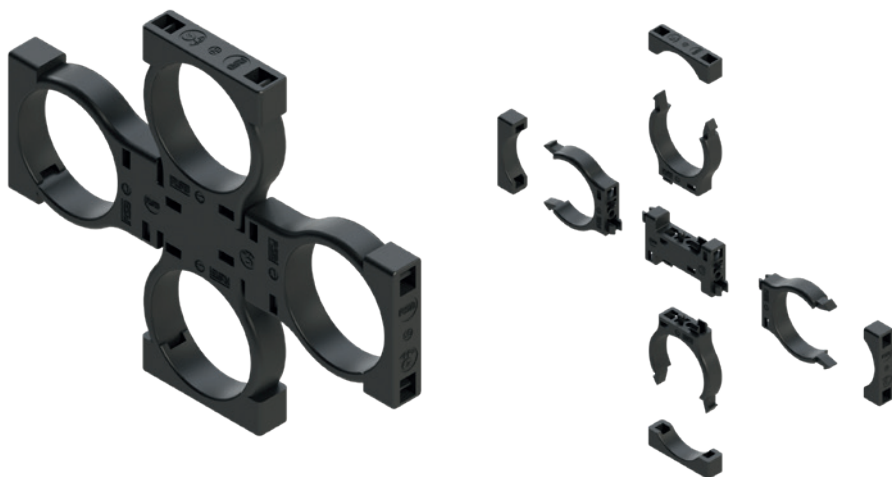
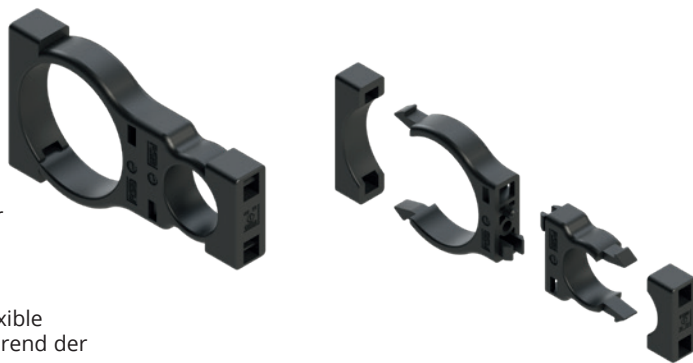

11 07

STAHL-KONSTRUKTIONSSCHELLE MIT ROHRUNTERLAGEN

**STEEL-CONSTRUCTION CLAMP
WITH TUBE SADDLES**

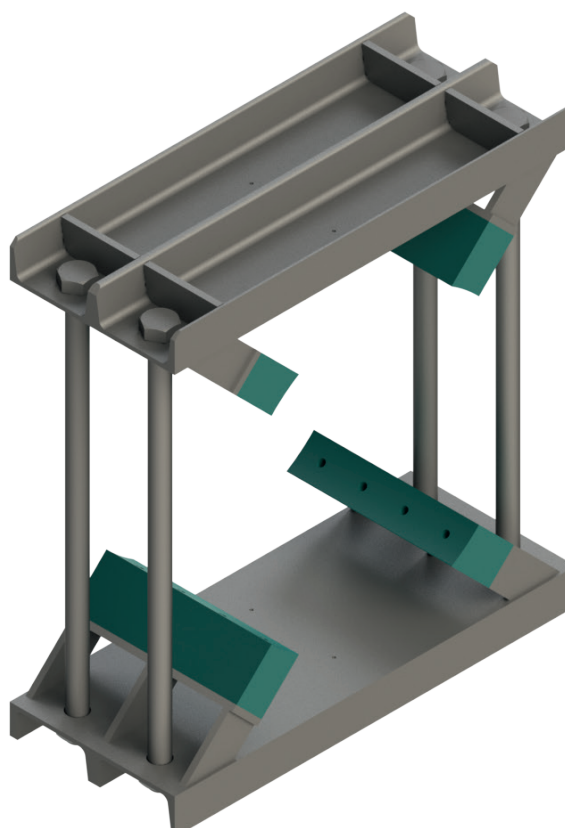

STAHL-KONSTRUKTIONSSHELLE MIT ROHRUNTERLAGEN | EINZELTEILE
STEEL-CONSTRUCTION CLAMP WITH TUBE SADDLES | COMPONENTS

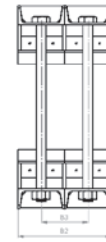
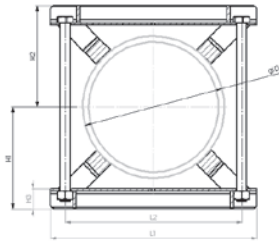
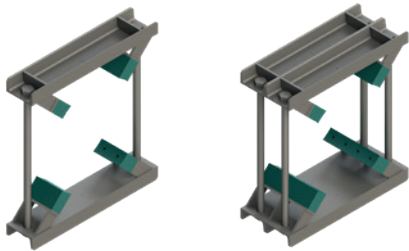

Rohr-AD mm O.D.mm D1	Stahl-Konstruktionsschelle Steel-construction clamp								Sechskantschraube Hexagon head screw	Anzahl der Rohrunterlagen Number of tube saddles
	L1	L2	H1	H2	H3	B1	B2	B3		
220 - 275	420	330	220	220	60	140	280	140	M30 x 370	4
276 - 325	460	370	240	240	60	140	280	140	M30 x 410	4
326 - 370	510	420	260	260	60	140	280	140	M30 x 450	4
371 - 425	570	480	290	290	60	140	280	140	M30 x 510	4
426 - 485	620	530	305	305	60	140	280	140	M30 x 540	4
486 - 550	680	590	370	370	60	140	280	140	M30 x 670	4
551 - 630	760	670	410	410	60	140	280	140	M30 x 750	5
631 - 715	845	755	452	452	60	140	280	140	M30 x 840	5
716 - 800	940	850	495	495	60	140	280	140	M30 x 920	5

// BESTELLBEISPIEL

RKP-355,6/CRVIF
 RRPD-273/Zn

RK P - 220 / CRVIF

Durchmesser
 220

Ausführung
 D = doppelt

Werkstoff (Rohrunterlagen)
 P = Polypropylen, N = Polyamid

RK = Stahl-Konstruktionsschelle mit Rohrunterlagen

Merkmale
 Zn = verzinkt
 CRVIF = chrom VI frei
 Phos = phosphatiert
 P = grundiert
 1.4571 = Edelstahl
 1.4301 = Edelstahl

// EXAMPLE OF ORDER

RKP-355,6/CRVIF
 RRPD-273/Zn

RK P - 220 / CRVIF

Diameter
 220

Version
 D = double

Material (tube saddles)
 P = polypropylene, N = polyamide

RK = Steel-construction clamp with tube saddles

Features
 Zn = zinc plated
 CRVIF = chromium VI free
 Phos = phosphated
 P = primed
 1.4571 = stainless steel
 1.4301 = stainless steel



// 07

FLACHSTAHLBÜGEL

FLAT STEEL U-BOLTS

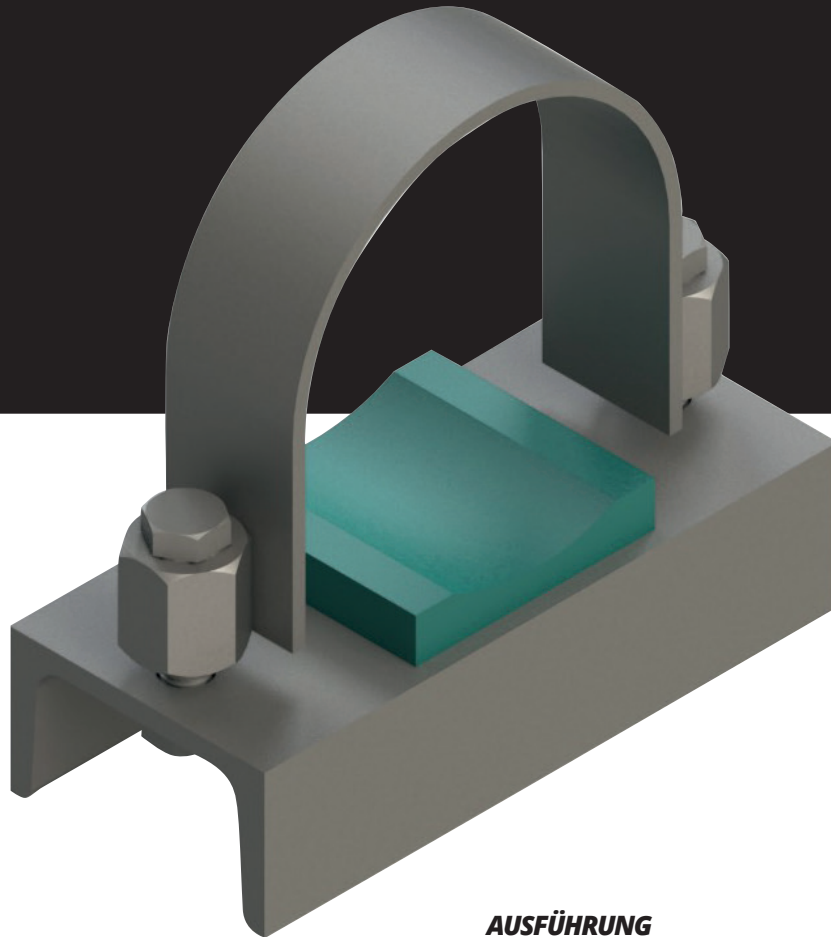

EINSATZBEREICH

Flachstahlbügel sind nur als Festpunkt-Befestigung einsetzbar

AREA OF APPLICATION

Flat steel U-bolts are to be used as fixed point-fastening only.

AUSFÜHRUNG

Flachstahlbügel mit U-Profil und kurzer Rohrunterlage KUPK.

Flachstahlbügel sind für Rohrdurchmesser von 48,3 bis 521 mm lieferbar.

Die Rohrunterlagen werden aus Polypropylen und Polyamid hergestellt.

CONSTRUCTION

Flat steel U-bolts with U-profile and short tube-saddle KUPK.

Flat steel U-bolts are available for tube diameters from 48,3mm to 521 mm.

The tube saddles are made of polypropylene and polyamide.



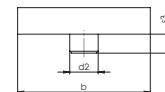
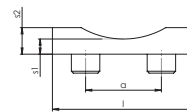
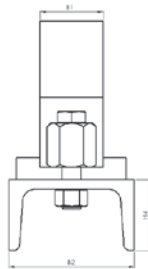
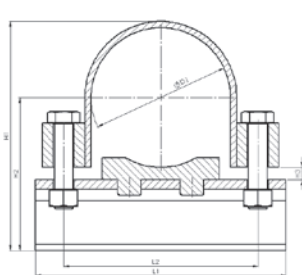
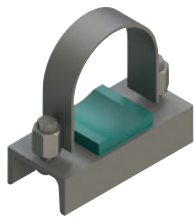

GRÖSSE SIZE	für Rohr for tube		Flachstahlbügel Flat steel U-bolt						U-Profil u-profile	Rohrunterlage, kurz Tube saddle, short						Sechskantschraube Hexagon head screw	
	D1	NW	L1	L2	H1	H2	H3	B1		B2 x H4	l	a	b	d2	s1		s2
40	48,3	1 1/2"	103	78	94	67	5	20 x 3	DIN 1026 50 x 38	24	25	35	8	5	8	5	M10 x 40
50	57	2"	115	87	103	71,5				38		50	10		10	6	
65	76,1	2 1/2"	132	106,1	122,1	81,1	8	40 x 4	DIN 1026 80 x 45	75	40	70	15	14	23	10	M12 x 55
80	88,9	3"	160	123,9	146	97,5											
100	108	4"	170	143	165	107											
125	133	5"	205	168	190	119,5											
	139,7			174,7	197	123											
150	159	6"	255	207	218	132,5											
	168,3			216,3	227,3	137,2											
175	193,7	8"	290	241,7	252,7	149,9											
200	216	8"	315	264	275	161											
	219,1			267	278	162,5											
250	267	10"	380	324	328	186,5											
	273			330	334	189,5											
300	318	12"	430	375	379	212											
	323,9			380,9	384,9	215											
350	355,6	14"	475	417,6	421,6	235,8											
	368			430	434	242											
400	406,4	16"	540	468,4	472,4	261,2											
	419			481	485	267,5											
	457			519	523	286,5											
500	508	20"	625	570	574	312											
	521			583	587	318,5											
							12	60 x 8	DIN 1026 100 x 50	220	150	75	30	30			M24 x 100

// BESTELLBEISPIEL

RUBF-88,9/Zn/KUPK-80

RUB F - 60,3 / CRVIF / KUPK - 50

RUB	F	-	60,3	/	CRVIF	/	KUPK	-	50
			Durchmesser				Nenngröße		
Variante F = flach							Rohrunterlage KUPK: Polypropylen KUNK: Polyamid		
Rohrbügel			Merkmale Zn = verzinkt CRVIF = chrom VI frei Phos = phosphatiert P = grundiert 1.4571 = Edelstahl 1.4301 = Edelstahl						

// EXAMPLE OF ORDER

RUBF-88,9/Zn/KUPK-80

RUB F - 60,3 / CRVIF / KUPK - 50

RUB	F	-	60,3	/	CRVIF	/	KUPK	-	50
			Diameter				Nominal size		
Version F = flat							Tube saddle KUPK: polypropylene KUNK: polyamide		
U-bolt			Features Zn = zinc plated CRVIF = chromium VI free Phos = phosphated P = primed 1.4571 = stainless steel 1.4301 = stainless steel						



// 07

RUNDSTAHLBÜGEL MIT ROHRUNTERLAGE FLACHSTAHL-ROHRSCHELLE

Stahl, verzinkt
und Edelstahl

U-BOLT WITH TUBE SADDLE FLAT STEEL TUBE CLAMP

steel, galvanized steel and stainless steel

EINSATZBEREICH

Eignung besonders zum Befestigen von Rohren mit Wärmeausdehnung. Die Rohre können mit dem Bügel wahlweise fest verspannt, oder mit Gleitspiel versehen werden.

AUSFÜHRUNG

Rundstahlbügel sind in zwei Ausführungen lieferbar:

RUBD Rundstahlbügel DIN 3570 mit 2 Muttern und **RUBL** Rundstahlbügel mit 4 Muttern unter Verwendung mit **KUPK** oder **KUPL** Rohrunterlagen. Rundstahlbügel sind für Rohrdurchmesser von 17 bis 762 mm lieferbar.

Die Rohrunterlagen werden in kurzer oder langer Ausführung aus Polypropylen und Polyamid hergestellt.

AREA OF APPLICATION

Especially suitable for securing tubes with heat expansion. The tubes can be braced firmly to the bow or, alternatively, slide along grooves.

CONSTRUCTION

U-bolts are available in two designs:

RUBD DIN 3570 with 2 nuts and **RUBL** U-bolts with 4 nuts to be used with tube saddle **KUPK** or **KUPL**. U-bolts are available for tube diameters from 17 to 762 mm.

The tube saddles are made of polypropylene and polyamide and are produced in a short or long version.

Rundstahlbügel mit
Rohrunterlage lang

U-bolt with
tube saddle long

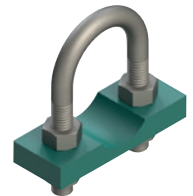

Rundstahlbügel mit
Rohrunterlage kurz

U-bolt with
tube saddle short

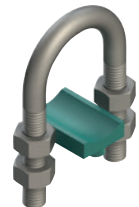

Rundstahlbügel

U-bolt



Flachstahl-
Rohrschelle

Flat steel
tube clamp



RUNDSTAHLBÜGEL DIN 3570 MIT 2 MUTTERN | EINZELTEILE U-BOLT WITH 2 NUTS DIN 3570 | COMPONENTS

Bestellzeichen:

Stahl
Stahl verzinkt
Edelstahl 1.4571

RUBD-*
RUBD-*/Zn
RUBD-*/1.4571

* mit Größe und Maß a ergänzen

Order codes:

Steel
Steel zinc plated
Stainless steel 1.4571

RUBD-*
RUBD-*/Zn
RUBD-*/1.4571

* complete with size and measure a

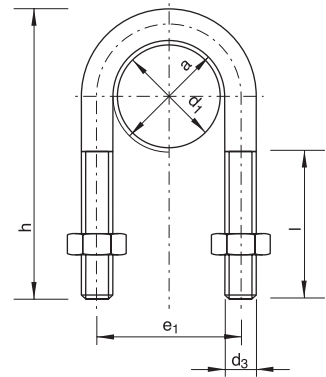

GRÖSSE SIZE	für Rohr for tube		RUBD Bestellzeichen Order Codes	a	l	d ₃	e ₁	h
	NW	d ₁						
15	3/8"	17,2	RUBD-15/24	24	40	M 10	34	65
	1/2"	21,3						
20	3/4"	25	RUBD-20/30	30	40	M 10	40	70
		26,9						
25	1"	30	RUBD-25/38	38	50	M 10	48	76
		33,7						
32	1 1/4"	38	RUBD-32/46	46	50	M 10	56	86
40	1 1/2"	44,5	RUBD-40/52	52			62	92
50	2"	57	RUBD-50/64	64	50	M 12	76	109
65	2 1/2"	60,3	RUBD-65/82	82			94	125
80	3"	76,1	RUBD-80/94	94	60	M 16	106	138
100	4"	88,9	RUBD-100/120	120			136	171
125	5"	108	RUBD-125/148	148	60	M 16	164	191
150	6"	114,3	RUBD-150/176	176			192	217
175		159	RUBD-175/202	202	60	M 16	218	249
200	8"	168,3	RUBD-200/228	228			248	283
250	10"	216	RUBD-250/282	282	70	M 20	302	334
300	12"	267	RUBD-300/332	332			352	385
350	14"	318	RUBD-350/378	378	70	M 24	402	435
400	16"	323,9	RUBD-400/428	428			452	487
500	20"	406,4	RUBD-500/530	530	70	M 24	554	589
		419						
		508						
		521						

Rundstahlbügel sind mit Rohrunterlagen kombinierbar. Bügel und Rohrunterlagen können auch einzeln bezogen werden.
RUBD mit KUPK oder KUPL sind als Gleit- und Festpunkt-Befestigung einsetzbar.
Lieferbar: ohne Oberflächenbehandlung, verzinkt und Edelstahl.

U-bolts be combined with tube saddles. U-bolts and tube saddles are also available in single pieces.
RUBD with KUPK or KUPL may be used as glide- or fixed point-fastening.
Available: without surface treatment, galvanized and stainless steel.



RUNDSTAHLBÜGEL MIT 4 MUTTERN | EINZELTEILE U-BOLT WITH 4 NUTS | COMPONENTS

Bestellzeichen:

Stahl **RUBL-***
Stahl verzinkt **RUBL-*/Zn**
Edelstahl 1.4571 **RUBL-*/1.4571**

* mit Größe und Maß a ergänzen

Order codes:

Steel **RUBL-***
Steel zinc plated **RUBL-*/Zn**
Stainless steel 1.4571 **RUBL-*/1.4571**

* complete with size and measure a

Rundstahlbügel ähnlich DIN 3570
U-Bolts similar to DIN 3570

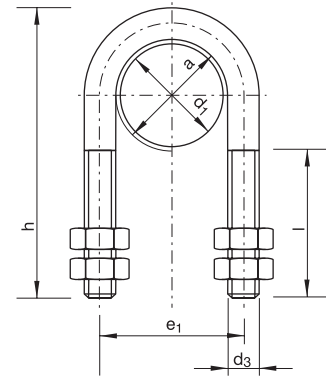
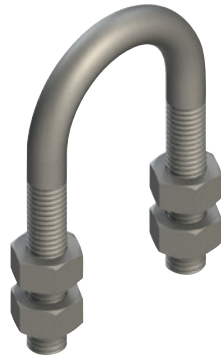

GRÖSSE SIZE	für Rohr for tube		RUBL Bestellzeichen Order Codes	a	l	d ₃	e ₁	h
	NW	d ₁						
15	3/8"	17,2	RUBL-15/24	24	40	M 10	34	70
	1/2"	21,3						
20	3/4"	25	RUBL-20/30	30	46		40	73,5
		26,9						
25	1"	30	RUBL-25/38	38	50		48	81
		33,7						
32	1 1/4"	38	RUBL-32/46	46			56	89
		42,4						
40	1 1/2"	44,5	RUBL-40/52	52	55		62	100
		48,3						
50	2"	57	RUBL-50/64	64	63	76	118	
		60,3						
65	2 1/2"	76,1	RUBL-65/82	82	77	94	135	
		88,9						
80	3"	88,9	RUBL-80/94	94	82	106	152	
100	4"	108	RUBL-100/120	120		136	190	
		114,3						
125	5"	133	RUBL-125/148	148	105	164	217	
		139,7						
150	6"	159	RUBL-150/176	176		192	247	
		168,3						
175		193,7	RUBL-175/202	202		218	273	
200	8"	216	RUBL-200/228	228		248	311	
		219,1						
250	10"	267	RUBL-250/282	282	125	302	364	
		273						
300	12"	318	RUBL-300/332	332		352	418	
		323,9						
350	14"	355,6	RUBL-350/378	378		402	475	
		368						
400	16"	406,4	RUBL-400/428	428	145	452	526	
		419						
500	20"	508	RUBL-500/530	530		554	627	
		521						
550		558,8	RUBL-550/570	570		600	689	
600		609,6	RUBL-600/622	622		652	741	
650		660,4	RUBL-650/680	680	175	710	795	
700		711,2	RUBL-700/730	730		760	845	
750		762	RUBL-750/785	785		815	898	

Rundstahlbügel sind mit Rohrunterlagen kombinierbar. Bügel und Rohrunterlagen können auch einzeln bezogen werden.
RUBL mit KUPK oder KUPL sind als Gleit- und Festpunkt-Befestigung einsetzbar.
Lieferbar: ohne Oberflächenbehandlung, verzinkt und Edelstahl.

U-bolts be combined with tube saddles. U-bolts and tube saddles are also available in single pieces.
RUBL with KUPK or KUPL may be used as glide- or fixed point-fastening.
Available: without surface treatment, galvanized and stainless steel.



Bestellzeichen:

Polypropylen
 Polyamid 6

KUPL-*
KUNL-*

* mit Größe und Durchmesser d_1 ergänzen

Bei Bedarf Standardkurzzeichen KUPL in der Spalte „Bestellzeichen“ austauschen.

Order codes:

Polypropylene
 Polyamide 6

KUPL-*
KUNL-*

* complete with size and diameter d_1

Replace standard abbreviation KUPL in column "Order codes" as required.

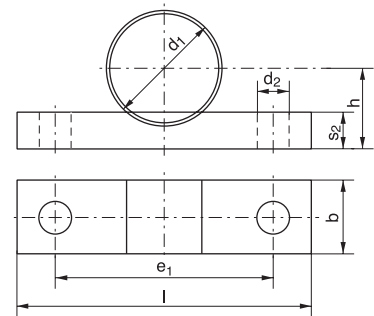
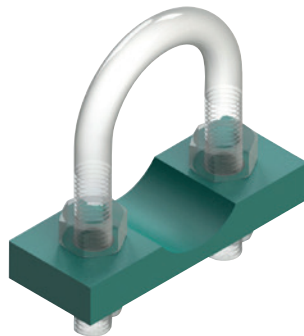

GRÖSSE SIZE	für Rohr for tube		KUPL Bestellzeichen Order Codes	l	b	s ₂	h	e ₁	d ₂
	NW	d ₁							
15	3/8"	17,2	KUPL-15/17,2	60	25	10	13,5	34	
	1/2"	21,3	KUPL-15/21,3				15,5		
20	3/4"	25	KUPL-20/25	75	30	12	17,5	40	
		26,9	KUPL-20/26,9				18,5		
25	1"	30	KUPL-25/30	80	35	15	20	48	11
		33,7	KUPL-25/33,7				22		
32	1 1/4"	38	KUPL-32/38	90	40	20	24	56	
		42,4	KUPL-32/42,4				26,2		
40	1 1/2"	44,5	KUPL-40/44,5	95	45	25	27,2	62	
		48,3	KUPL-40/48,3				29		
50	2"	57	KUPL-50/57	110	50	30	33,5	76	14
		60,3	KUPL-50/60,3				35,2		
65	2 1/2"	76,1	KUPL-65/76,1	135	55	35	43	94	
80	3"	88,9	KUPL-80/88,9	145	60	40	54,5	106	
100	4"	108	KUPL-100/108	190	65	45	64	136	
		114,3	KUPL-100/114,3				67		
125	5"	133	KUPL-125/133	220	70	50	76,5	164	18
		139,7	KUPL-125/139,7				80		
150	6"	159	KUPL-150/159	250	75	55	91,5	192	
		168,3	KUPL-150/168,3				96		
175	8"	193,7	KUPL-175/193,7	270	80	60	109	218	
		216	KUPL-200/216				120		
200	10"	219,1	KUPL-200/219,1	315	85	65	121,5	248	
		267	KUPL-250/267				145,5		
250	12"	273	KUPL-250/273	370	90	70	148,5	302	22
		318	KUPL-300/318				174		
300	14"	323,9	KUPL-300/323,9	420	95	75	177	352	
		355,6	KUPL-350/355,6				193		
350	16"	368	KUPL-350/368	480	100	80	199	402	
		406,4	KUPL-400/406,4				218		
400	18"	419	KUPL-400/419	540	105	85	224,5	452	26
		508	KUPL-500/508				269		
500	20"	521	KUPL-500/521	640	110	90	276	554	
		558,8	KUPL-550/558,8				300		
600		609,6	KUPL-600/609,6	750	115	95	325	652	
650		660,4	KUPL-650/660,4	810	120	100	350	710	33
700		711,2	KUPL-700/711,2	870	125	105	376	760	
750		762	KUPL-750/762	910	130	110	401	815	

ROHRUNTERLAGE, KURZ | EINZELTEILE
TUBE SADDLE, SHORT | COMPONENTS

Bestellzeichen:

Polypropylen
 Polyamid 6

KUPK-*
KUNK-*

* mit Größe und Durchmesser d_1 ergänzen

Bei Bedarf Standardkurzzeichen KUPK in der Spalte „Bestellzeichen“ austauschen.

Order codes:

Polypropylene
 Polyamide 6

KUPK-*
KUNK-*

* complete with size and diameter d_1

Replace standard abbreviation KUPK in column "Order codes" as required.

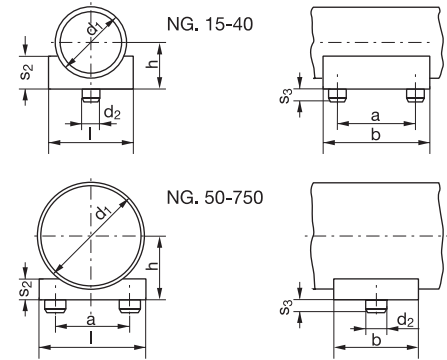
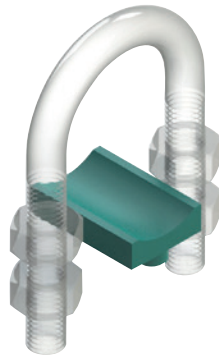

GRÖSSE SIZE	für Rohr for tube		KUPK Bestellzeichen Order Codes	l	b	s ₂	h	a	d ₂	s ₃																																								
	NW	d ₁																																																
15	3/8"	17,2	KUPK-15/17,2	24	35	8	13,6	25	8	5																																								
	1/2"	21,3	KUPK-15/21,3				15,65																																											
20	3/4"	25	KUPK-20/25				38				50	10	17,5	10	6																																			
		26,9	KUPK-20/26,9										18,45																																					
25	1"	30	KUPK-25/30										75			70	14	20	90	25																														
		33,7	KUPK-25/33,7															21,85																																
32	1 1/4"	38	KUPK-32/38															140			75	23	24	150	30																									
		42,4	KUPK-32/42,4																				26,2																											
40	1 1/2"	44,5	KUPK-40/44,5																				220			75	30	27,25	150	30																				
		48,3	KUPK-40/48,3																									29,15																						
50	2"	57	KUPK-50/57																									300			75	38	33,5	220	30															
		60,3	KUPK-50/60,3																														35,15																	
65	2 1/2"	76,1	KUPK-65/76,1																														300			75	38	43,05	220	30										
80	3"	88,9	KUPK-80/88,9																																			52,45												
		100	4"																																			108			KUPK-100/108	62								
114,3	KUPK-100/114,3																																					65,15												
125	5"	133	KUPK-125/133																																			300			75	38	74,5	220	30					
		139,7	KUPK-125/139,7																																								77,85							
150	6"	159	KUPK-150/159																																								300			75	38	87,5	220	30
		168,3	KUPK-150/168,3																																													92,15		
175	8"	193,7	KUPK-175/193,7	300	75	38		104,85	220	30																																								
		200	10"					216																																								KUPK-200/216		
219,1	KUPK-200/219,1						117,55																																											
250	12"	267	KUPK-250/267				300	75			38	141,5		220	30																																			
		273	KUPK-250/273									144,5																																						
300	14"	318	KUPK-300/318									300	75			38	167		220	30																														
		323,9	KUPK-300/323,9														169,95																																	
350	16"	355,6	KUPK-350/355,6														300	75			38	185,8		220	30																									
		368	KUPK-350/368																			192																												
400	20"	406,4	KUPK-400/406,4																			300	75			38	211,2		220	30																				
		419	KUPK-400/419																								217,5																							
500	24"	508	KUPK-500/508																								300	75			38	262		220	30															
		521	KUPK-500/521																													268,5																		
550		558,8	KUPK-550/558,8																													300	75			38	287,4		220	30										
600		609,6	KUPK-600/609,6																																		312,8													
650		660,4	KUPK-650/660,4																																		300											75		
700	30"	711,2	KUPK-700/711,2																																			363,6												
		750																																				762			KUPK-750/762	389								

FLACHSTAHL-ROHRSCHELLEN DIN 3567 (FORM A) | EINZELTEILE
FLAT STEEL TUBE CLAMPS DIN 3567 (SERIES A) | COMPONENTS

Bestellzeichen:

Stahl
 Stahl feuerverzinkt
 Edelstahl 1.4571

FRD-*A
FRD-*A/FZn
FRD-*A/1.4571

* mit Größe ergänzen

Order codes:

Steel
 Steel hot-dip galvanized
 Stainless steel 1.4571

FRD-*A
FRD-*A/FZn
FRD-*A/1.4571

* complete with size

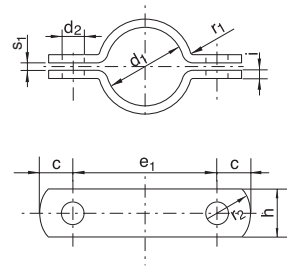

GRÖSSE SIZE d ₁	FRD Bestellzeichen Order Codes	Für Rohr Nennweite For tube NB	Maße Measurements							erforderl. Schrauben mit Mutter Matching screws with nut									
			e ₁	c	d ₂	s ₁	r ₁	r ₂	h		i								
20	FRD-20 A	15	57	15	11,5	7	4	18	30	5	M 10 x 30								
22	FRD-22 A		1/2"									59							
25	FRD-25 A	20	62																
27	FRD-27 A		3/4"									66							
30	FRD-30 A	25	68																
34	FRD-34 A		1"									72							
38	FRD-38 A	32	76																
43	FRD-43 A		1 1/4"									82							
45	FRD-45 A	40	84																
49	FRD-49 A		1 1/2"									88							
57	FRD-57 A	50	104									18	14	9	6	24	40	6	M 12 x 35
61	FRD-61 A		2"																
77	FRD-77 A	2 1/2"	122																
89	FRD-89 A	3"	136																
108	FRD-108 A	100	172																
115	FRD-115 A		4"	178															
133	FRD-133 A	125	196	24	18	11	6	30	50	8	M 16 x 45								
140	FRD-140 A		5"									204							
159	FRD-159 A	150	222																
169	FRD-169 A		6"									232							
191	FRD-191 A	175	254																
194	FRD-194 A		258																
216	FRD-216 A	200	280																
220	FRD-220 A		8"									284							
267	FRD-267 A	250	342									30	23	14	8	36	60	8	M 20 x 50
273	FRD-273 A		10"																
318	FRD-318 A	300	392																
324	FRD-324 A		12"	398															
356	FRD-356 A	350	432																
368	FRD-368 A		444																
407	FRD-407 A	400	498	36	27	18	8	42	70	10	M 24 x 60								
419	FRD-419 A		510																
508	FRD-508 A	500	600																
521	FRD-521 A		614																

Lieferbar: ohne Oberflächenbehandlung, verzinkt und Edelstahl.
 Available: without surface treatment, galvanized and stainless steel.



// 08

BEZEICHNUNGSSYSTEM

Flexible Montage, informative Kennzeichnung, variabler Anwendungsbereich

LABELING SYSTEM

Flexible assembly, informative symbols, variable areas of application

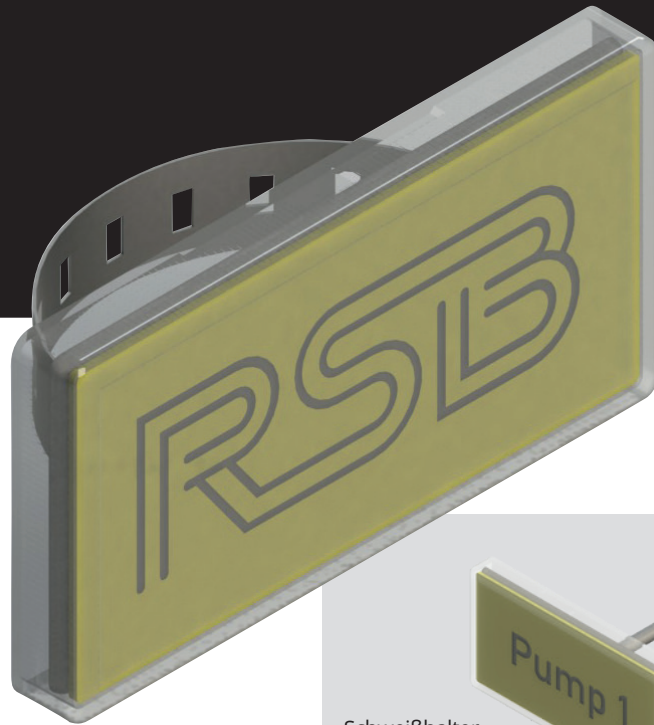

DAS SYSTEM

Das RSB-Bezeichnungssystem besteht aus Schilderhalterungen, an welchen die Bezeichnungsschilder durch Aufklipsen der Schutzabdeckung befestigt werden.

EINSATZBEREICH

Die Vielfalt der Befestigungsmöglichkeiten, von der einfachen Schraubmontage über Spannbänder, bis zur speziellen Halterung für isolierte Rohre, ermöglicht alle in der Praxis vorkommenden Bezeichnungsarten:

- Gebäudeinstallation mit Gas-, Wasser-, Elektro- und Heizungsanlagen
- industrielle Installation in der Schiffs-, Flug- und Bergwerktechnik, sowie im Hydraulik- und Schaltanlagenbereich

HALTBARKEIT

Durch die Schutzwirkung der Abdeckkappe sind die Informationen auch noch nach Jahren lesbar. Sie sind leicht zu reinigen oder auszuwechseln und bieten einen optimalen Schutz vor Umwelteinflüssen.

THE SYSTEM

The RSB-Labeling system consists of plates support and cover, into which the engraved plate of solid or double layer material is inserted.

AREAS OF APPLICATION

The versatility of fixing possibilities, from the simplest screw assembly via straps to special supports for insulated tubes, enables every in practice occurring type of labelling:

- Building systems with gas, water, electro and heating installations
- industrial installations in the naval, aero and mining technology, as well as in the hydraulic and switchgear field

STABILITY

The protective effect of the cover ensures that the data is still legible, even after years. It can easily be cleaned or changed and offers optimal protection against environmental influences.

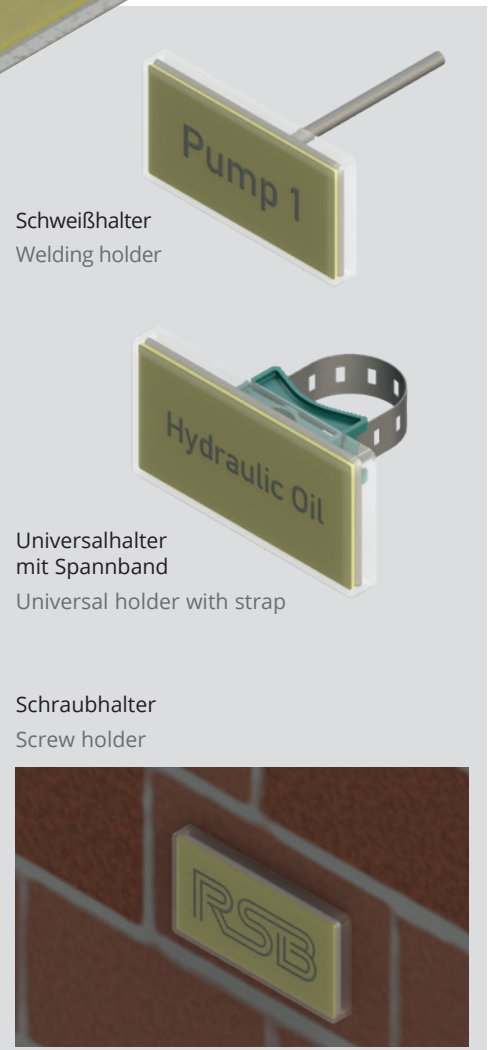

Schweißhalter
Welding holder

Universalhalter
mit Spannbänder
Universal holder with strap

Schraubhalter
Screw holder



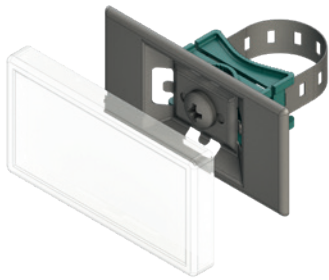

UNIVERSALHALTER / UNIVERSAL HOLDER

Komplett mit Kunststoffabdeckung und verzinktem Spannband.
Passend für Rohre bis 2 1/2".

Complete with plastic cover and galvanized steel strap.
For tubes up to 2 1/2".

Bestellzeichen / Order code: UNH

Verpackung 25 Stück / Packs of 25



SCHWEISSHALTER / WELDING HOLDER

Komplett mit Kunststoffabdeckung und Anschweißstift 100 mm lang.
Complete with plastic cover and 100 mm welding pin.

Bestellzeichen / Order code: SWH

Verpackung 25 Stück / Packs of 25



SCHRAUBHALTER / SCREW HOLDER

Komplett mit Kunststoffabdeckung, ange-
nieteter Mutter M 8 und zwei zusätzlichen
Schraublöchern Ø 4 mm.

Complete with plastic cover, M 8 nut and
two additional screw holes Ø 4 mm.

Bestellzeichen / Order code: SRH

Verpackung 25 Stück / Packs of 25



SPANNBAND / STRAP

Passend für Universalhalter.
Einsatz für Rohre > 2 1/2".

Suitable for the universal holder.
Use with tubes > 2 1/2".

Bestellzeichen / Order codes:
Stahl verzinkt / Galvanized steel: **SPR/Zn**
Edelstahl / Stainless steel 1.4571: **SPR/1.4571**

Verpackung 1 Rolle á 5 m / Packed in 5 m rolls



**KUNSTSTOFFABDECKUNG /
PLASTIC COVER**

Glasklar, passend zu allen Haltertypen.
Transparent, suitable for all holder types.

Bestellzeichen / Order code: KAD

Abmessung 105 x 55 mm /
Measurement 105 x 55 mm

Verpackung 50 Stück / Packs of 50



**SCHILD GRAVIERT /
ENGRAVED PLATE**

Zweischicht-Kunststoff, Schrift weiß,
graviert nach Kundenwunsch.

Double-layer plastic, white lettering,
engraved to order.

**Bestellzeichen- Order codes-
Farben colours:**
SGR-rot SGR-red
SGR-blau SGR-blue
SGR-grün SGR-green
SGR-gelb SGR-yellow

Abmessung 100 x 50 mm /
Measurement 100 x 50 mm

Verpackung 25 Stück /
Packs of 25

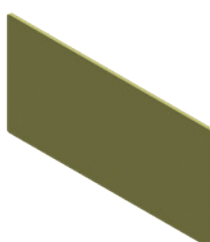

**SCHILD GLATT /
SMOOTH PLATE**

Glatte Oberfläche zum Aufkleben
von Prägebändern.

Smooth surface for the adhesion
of stamped strips.

**Bestellzeichen- Order codes-
Farben colours:**
SGL-rot SGL-red
SGL-blau SGL-blue
SGL-grün SGL-green
SGL-gelb SGL-yellow

Abmessung 100 x 50 mm /
Measurement 100 x 50 mm

Verpackung 25 Stück /
Packs of 25

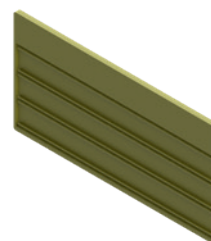

**LEERSCHILD MIT NUTEN/
EMPTY GROOVED PLATE**

Mit Nuten zum Einschieben
von Prägebändern 9,5 mm.

With grooves for inserting
stamped strips 9,5 mm.

**Bestellzeichen- Order codes-
Farben colours:**
SNU-rot SNU-red
SNU-blau SNU-blue
SNU-grün SNU-green
SNU-gelb SNU-yellow

Abmessung 100 x 50 mm /
Measurement 100 x 50 mm

Verpackung 25 Stück /
Packs of 25

Metallteile auch in Edelstahl lieferbar.
All metal parts available in stainless steel.





***// WIR SIND EIN MITTELSTÄNDISCHES
UNTERNEHMEN DER FEINWERK-
TECHNIK, KUNSTSTOFFVERARBEITUNG
UND BELEUCHTUNGSTECHNIK.***

***// WE OPERATE A MEDIUM-SIZED BUSINESS IN THE FIELD
OF PRECISION ENGINEERING, PLASTICS PROCESSING AND
LIGHTING ENGINEERING.***

// WIR ÜBER UNS

Wir sind ein mittelständisches Unternehmen der Feinwerktechnik, Kunststoffverarbeitung und Beleuchtungstechnik.

Wir stanzen, biegen, schweißen auf modernsten Maschinen. Unser Know-how in der spanlosen Fertigung macht uns zu einem leistungsfähigen Hersteller in der Blechverarbeitung. Die spanabhebende Fertigung gibt uns die Möglichkeit, spezielle Kundenwünsche schnell zu realisieren. Flexibilität ist die Stärke unserer Kunststoffverarbeitung.

Wir vereinen zwei Produktbereiche in unserem Haus:

- **RSB** – Rohrschellen
- **TECHMALUX®** – Lichttechnik

// SO ERREICHEN SIE UNS

Oberndorf liegt im Neckartal, zwischen Schwarzwald und Schwäbischer Alb, verkehrsgünstig an der BAB Stuttgart – Westlicher Bodensee (A 81) mit eigener Anschlussstelle und an der B 14 zwischen Rottweil und Horb.

Es bestehen Bahnverbindungen zu allen größeren Städten der Umgebung, sowie in die Schweiz und Italien.

// WE ABOUT US

We operate a medium-sized business in the field of precision engineering, plastics processing and lighting engineering.

We stamp, bend, weld on state-of-the-art-machines. Our know-how in the field of chipless production makes us an efficient manufacturer in sheet metal processing. Our cutting shaping equipment allows us to realise our customers' wishes without delay. Our plastics processing's strenght lies in its flexibility.

We combine two product ranges under one roof:

- **RSB** – Tube Clamps
- **TECHMALUX®** – Lighting Technology

// THAT'S HOW TO GET TO US

Oberndorf is situated in the Neckartal, a valley conveniently situated between the Black Forest and the Swabian mountains and has an own junction to the A 81, the federal motorway between Stuttgart and the Western part of the Lake Constance region. Oberndorf is situated between cities of Rottweil and Horb.

The railway system is connected to all major cities in the surrounding region well as to Switzerland and Italy.





**FEINWERKTECHNIK
KUNSTSTOFFVERARBEITUNG
BELEUCHTUNGSTECHNIK**

Wehrstrasse 15/27
D-78727 Oberndorf

Tel.: +49 (0) 7423/9298-0
Fax: +49 (0) 7423/9298-55

FKB@FKB-GMBH.COM
WWW.FKB-GMBH.COM